

**NOTICE DE MONTAGE
ASSEMBLY INSTRUCTIONS
INSTRUCCIONES DE MONTAJE
MONTAGE-INSTRUCTIE**

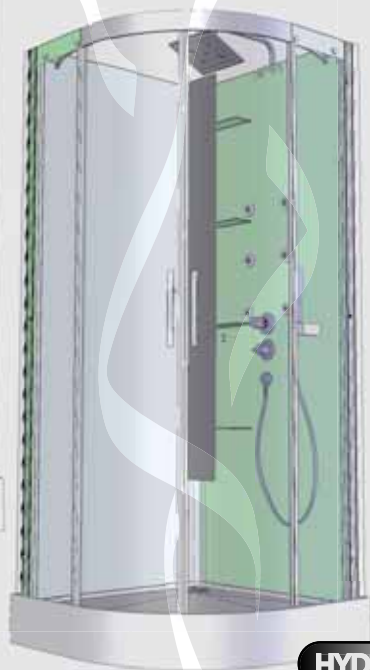

HYDRO

Kinedo

DES 550B

GUARANTEE

You have just acquired a quality product, and the objective of the following text is to provide you with information on the conditions of guarantee and the useful life of your shower unit.

- ✓ **There is a two-year guarantee on your shower unit** (as from the date of purchase: your invoice provides proof)
- ✓ The nominal guarantee is that of the general conditions of sale.

Reminder of the conditions of guarantee and exclusions

CONDITIONS. The installation must be in compliance with standards and with good professional practice. This installation must comply with the following obligations:

- A supply of hot water at a constant temperature of between 55°C and 65°C is preferable (hot water tank, immersion heater, etc.).
- The pressure in the hot and cold water supplies must be between a minimum of 3 bars and a maximum of 5 bars. A pressure differential of one bar between the hot and cold water supplies can lead to incorrect operation.
- On manufacture, your thermostatically controlled mixer tap is set to 38°C. If a temperature difference occurs, calibrate the cartridge (See instructions for use, page 14)
- When installing new copper pipes, bleed them before connecting them up definitively to the taps (Any remaining impurities could block the filters or the mixer tap).

EXCLUSIONS. The following are excluded from the guarantee:

- Poor conditions of installation of the shower unit: floor not level, electrical installation not in conformity with standards, failure to comply with assembly instructions.
- Poor functioning of the taps: insufficient or excess mains water pressure, water heater insufficient.
- Breakage of glass though a physical gesture or other circumstances such as external vibrations, etc.
- A product that has obviously been modified.

TECHNICAL SUPPORT – REPAIRS

The maximum temperature is too low as compared with the temperature of the hot water supply.

- Check that the filters are clean, and clean them if necessary.

The water flow rate drops over time.

- Clean or replace the filters on the mixer tap.

The water is not at the right temperature.

- Check that pressure levels of the hot and cold water supplies are similar.
- Check that the supply hoses are not pinched.









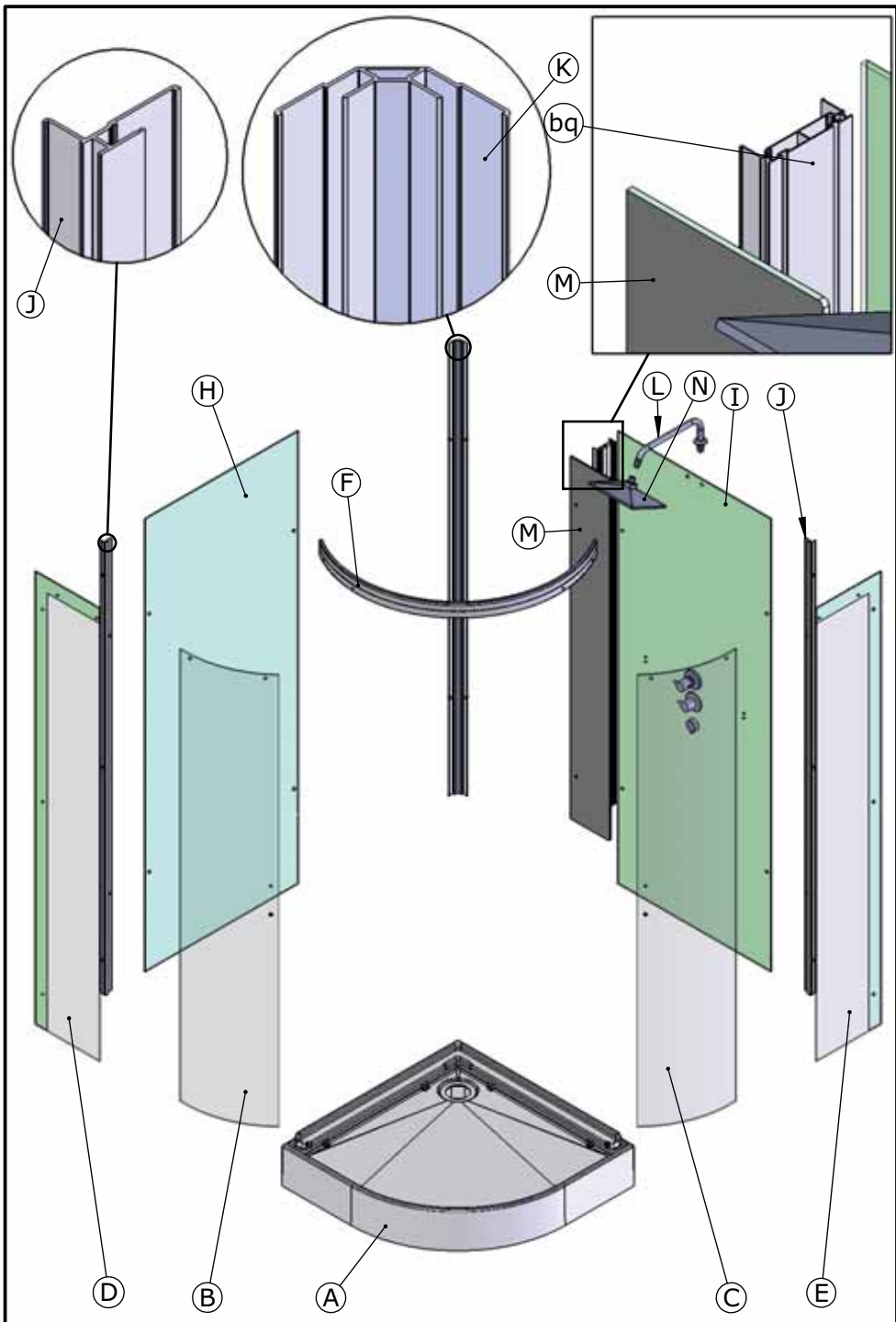







When the unit is put into service, the water is either always hot or always cold.

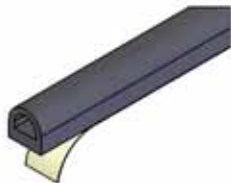



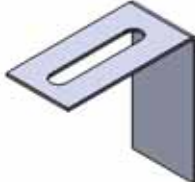









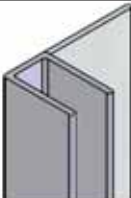

- The inlet pipes have been connected up the wrong way round.



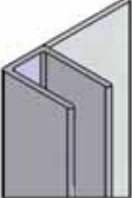
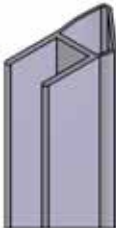
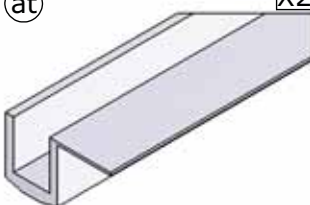









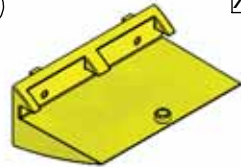

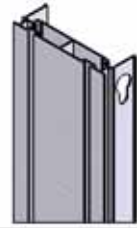
The mixed water flows in spurts and at low flow rates except at extreme temperatures.

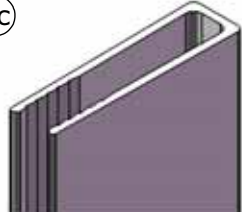
- One of the water supplies is insufficient.
- The filters are clogged.

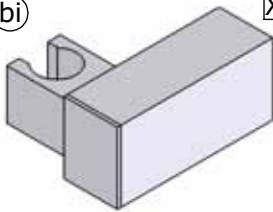
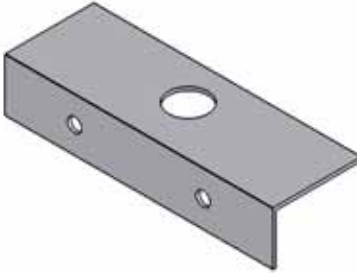

<p>o X2</p> 	<p>p X2</p> 	<p>q X8</p>  <p style="text-align: center;">1=1</p>
<p>r X2</p>  <p style="text-align: center;">1=1</p>	<p>s X1</p> 	
<p>t X22</p> 	<p>u X18</p>  <p style="text-align: center;">1=1</p>	<p>v X22</p> 
<p>w</p> 	<p>x X1</p> 	<p>y X2</p>  <p style="text-align: center;">1=1</p>
<p>z X2</p>  <p style="text-align: center;">1=1</p>	<p>aa X2</p>  <p style="text-align: center;">1=1</p>	<p>ab X2</p> 
<p>ac X2</p>  <p style="text-align: center;">1=1</p>	<p>ad X1</p> 	<p>ae X1</p> 

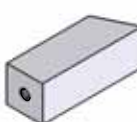
<p>(af) X2</p>  <p>1=1</p>	<p>(ag) X2</p>  <p>1=1</p>	<p>(ah) X2</p> 
<p>(ak) X2</p> 	<p>(al) X2</p>  <p>Lg = 1925 mm</p>	<p>(am) X2</p> 
<p>(an) X2</p>  <p>1=1</p>	<p>(ao) X2</p> 	<p>(ap) X2</p> 
<p>(aq) X2</p> 	<p>(ar) X2</p>  <p>Lg = 1997 mm</p>	<p>(as) X2</p> 
<p>(at) X2</p> 	<p>(au) X4</p> 	<p>(av) X2</p>  <p>1=1</p>
<p>(aw) X2</p> 	<p>(ax) X2</p> 	<p>(ay) X2</p> 

<p>(bm) X2</p>  <p>1=1</p>	<p>(bn) X2</p>  <p>1=1</p>	<p>(bo) X4</p> 
<p>(bp) X8</p>  <p>1=1</p>	<p>(bq) X1</p> 	<p>(bb) X4</p>  <p>1=1</p>
<p>(bc) X2</p> 	<p>(bd) X2</p> 	<p>(br) X4</p> 
<p>(bf) X2</p>  <p>1=1</p>	<p>(bg) X2</p>  <p>1=1</p>	<p>(bi) X1</p> 
<p>(bh) X1</p> 	<p>(bj) X1</p> 	
<p>(bk) X2</p> 	<p>(bl) X4</p>  <p>1=1</p>	

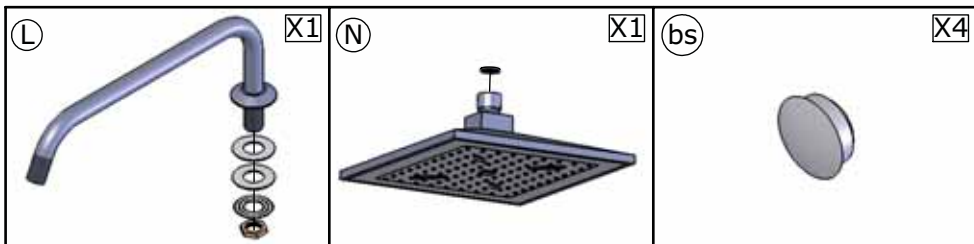

Les quantités données sont les quantités utiles au montage.
Les sachets fournis contiennent des pièces supplémentaires.

The quantities given are what are required for the installation.
There may be some surplus parts in the package provided.

Las cantidades indicadas son las cantidades necesarias para el montaje.
Las bolsitas incluidas contienen piezas suplementarias.

De aangegeven hoeveelheid toont het aantal onderdelen dat voor montage nodig is.
De meegeleverde zakjes kunnen meer onderdelen bevatten.

Matériel nécessaire :
Tools required :
Material necesario :
Nodige gereedschap :

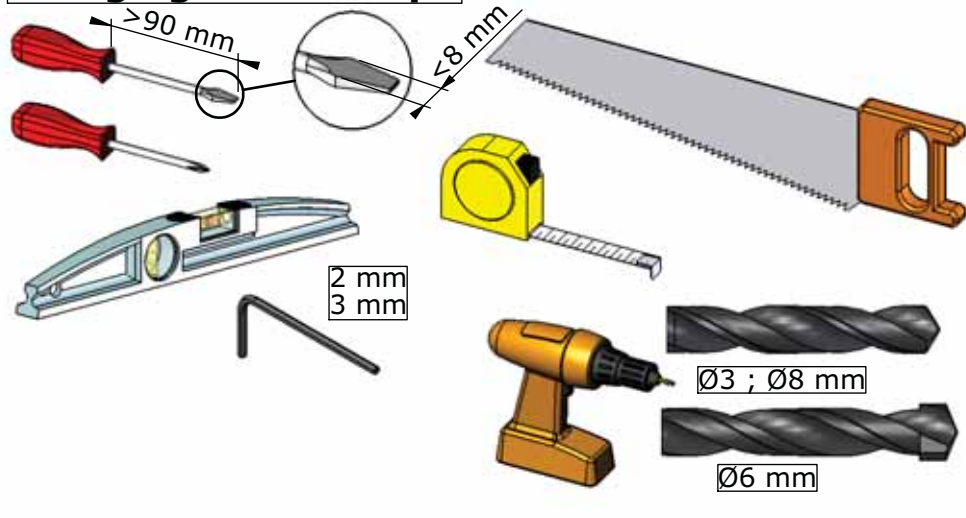

X2

Nous conseillons deux personnes pour assembler la cabine
Requires 2 person assembly

MONTAGE A DROITE
RIGHT HAND
MONTAJE A LA DERECHA
MONTAGE RECHTS

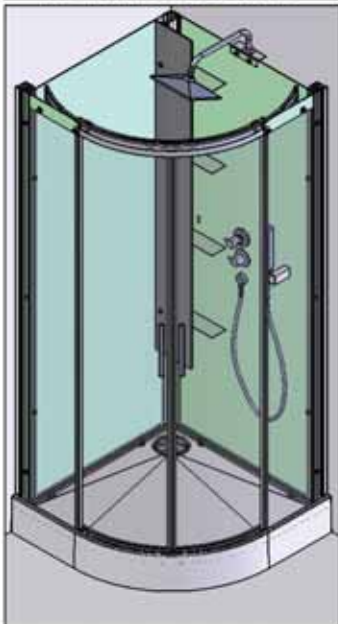

MONTAGE A GAUCHE
LEFT HAND
MONTAJE A LA IZQUIERDA
MONTAGE LINKS

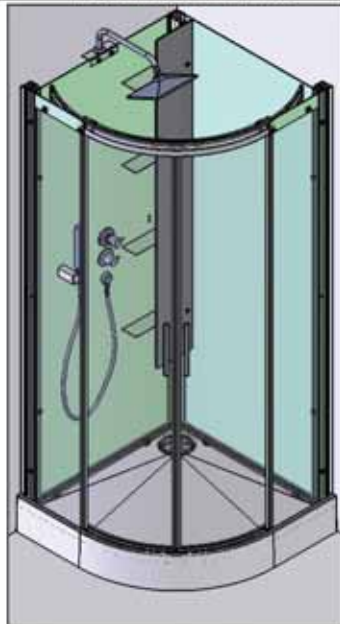

Vous avez la possibilité de réaliser un montage à droite ou un montage à gauche. Notre notice d'installation décrit un montage à droite. si vous voulez réaliser un montage à gauche, il vous suffit d'inverser le montage.

This cubicle can be installed either left or right hand. These installation instruction show a right hand installation.

Puede realizar un montaje a la derecha o un montaje a la izquierda. Nuestro folleto de instalación describe un montaje a la derecha. Si desea montar su cabina a la izquierda sólo tendrá que realizar el montaje al contrario.

U kunt de cabine rechts of links monteren. Onze handleiding beschrijft de rechtse montage van de cabine. Keer de montage om als u de cabine links wilt monteren.

01

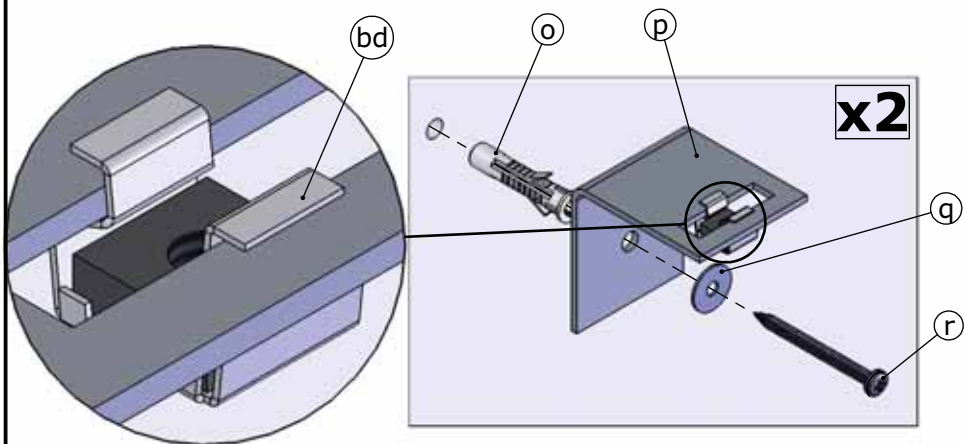
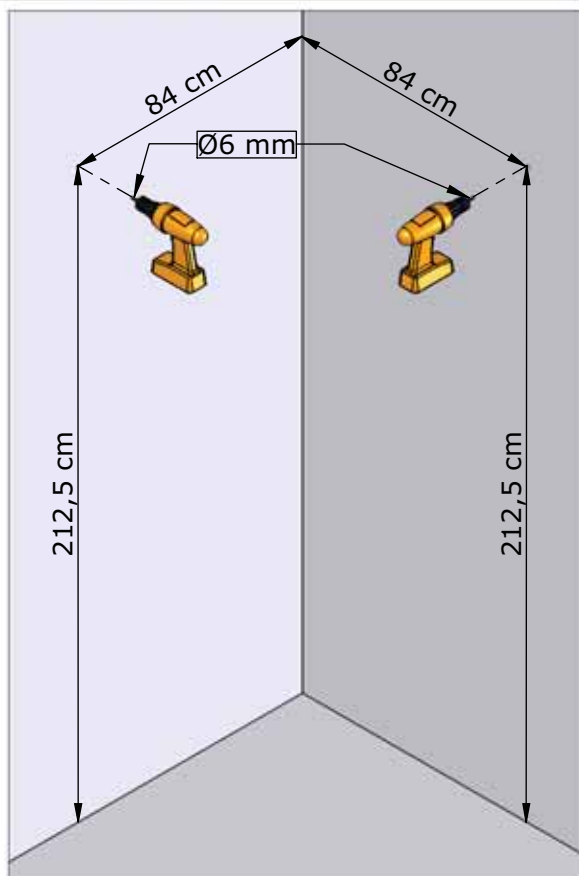

02

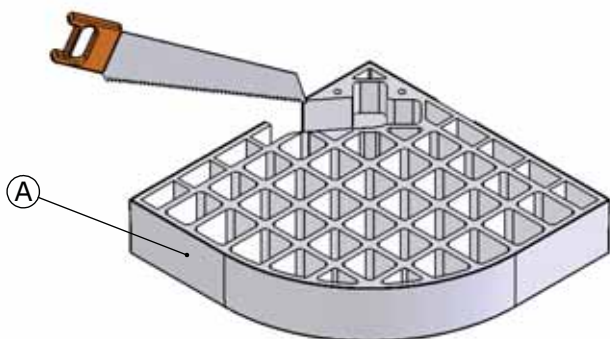
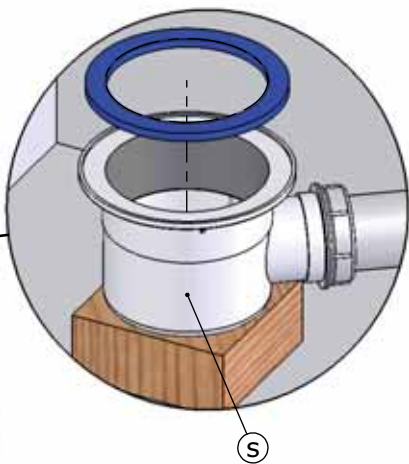
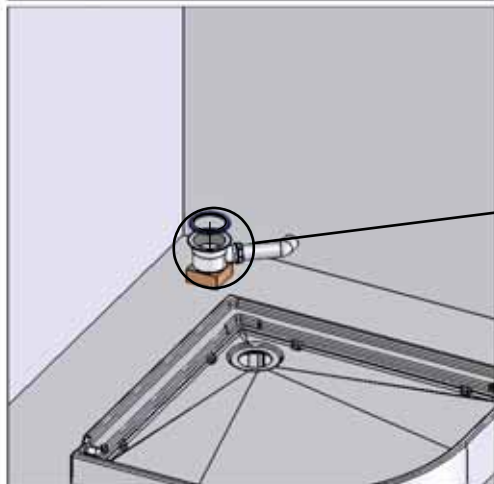
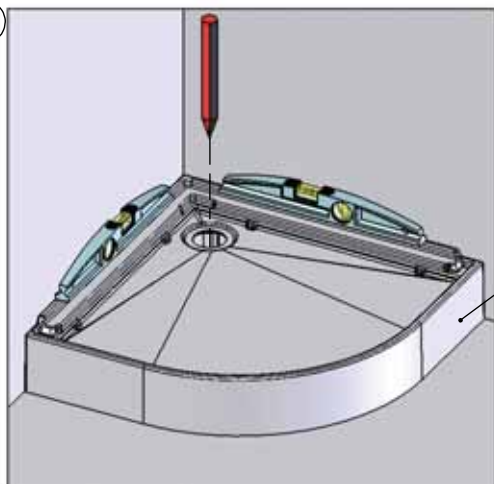

03

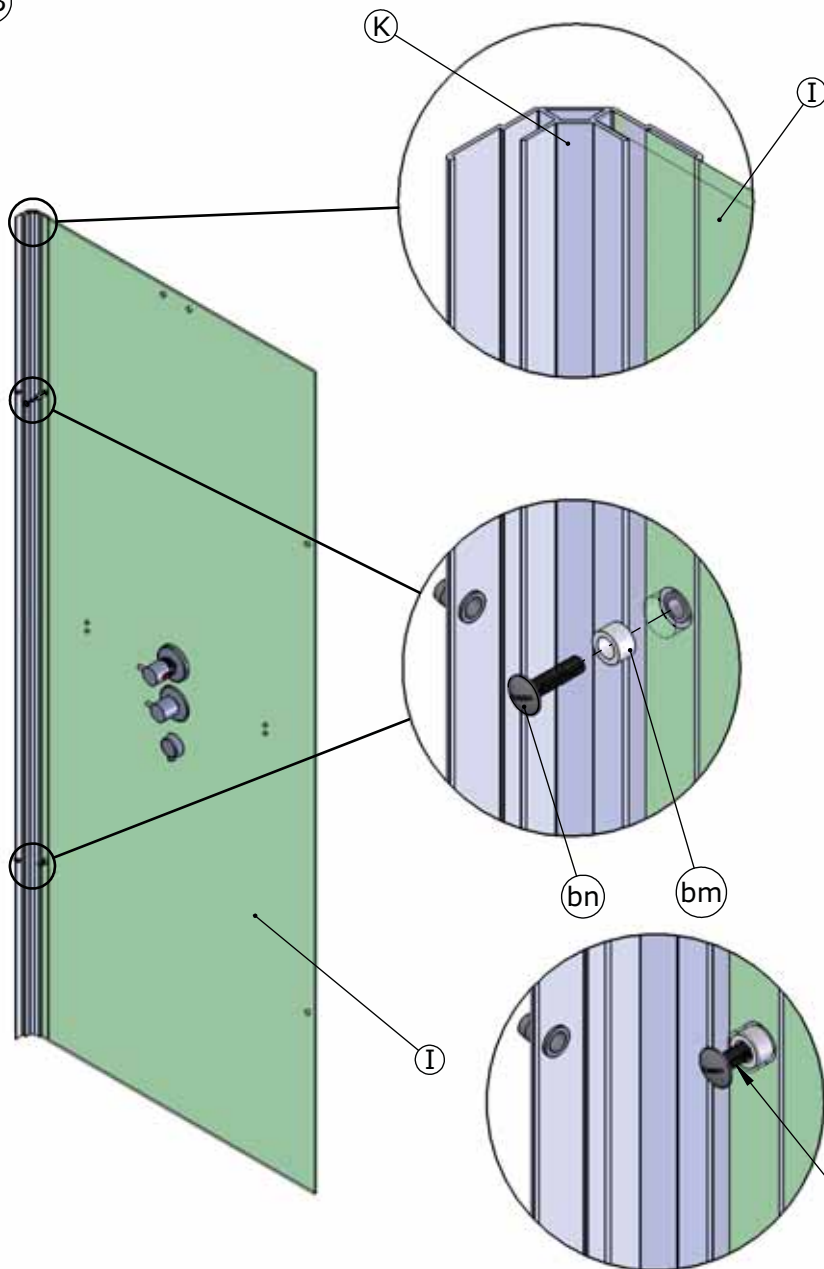

LAISSER UN JEU ENTRE LA VIS ET LE VERRE.
 LEAVE SOME PLAY FOR ADJUSTEMENT.
 DEJE UN ESPACIO ENTRE EL TORNILLO Y EL CRISTAL.
 EEN BEETJE SPELING LATEN TUSSEN DE SCHROEF EN HET GLAS.

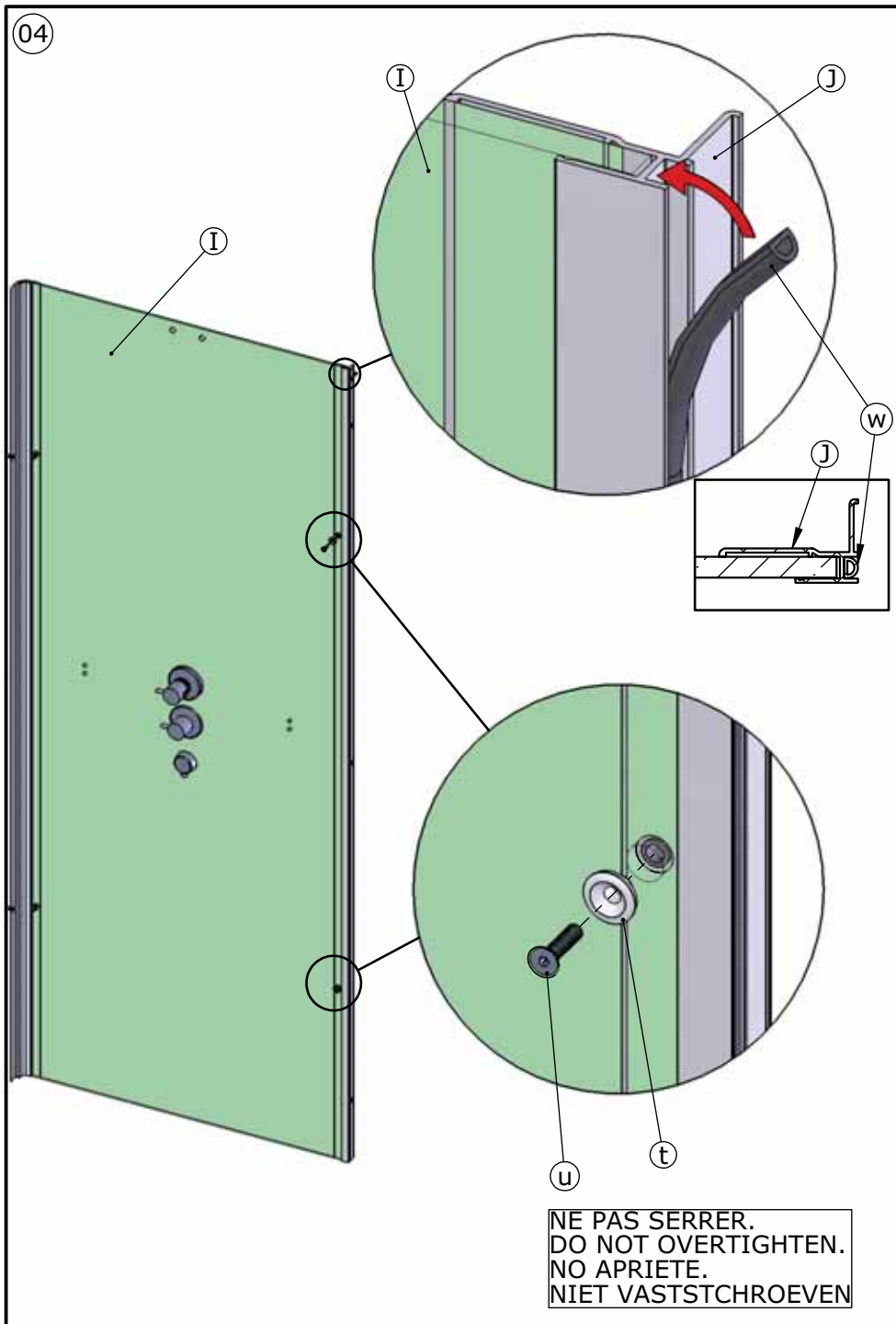

05

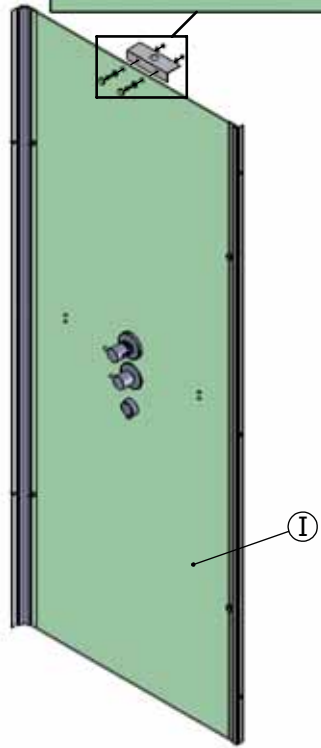
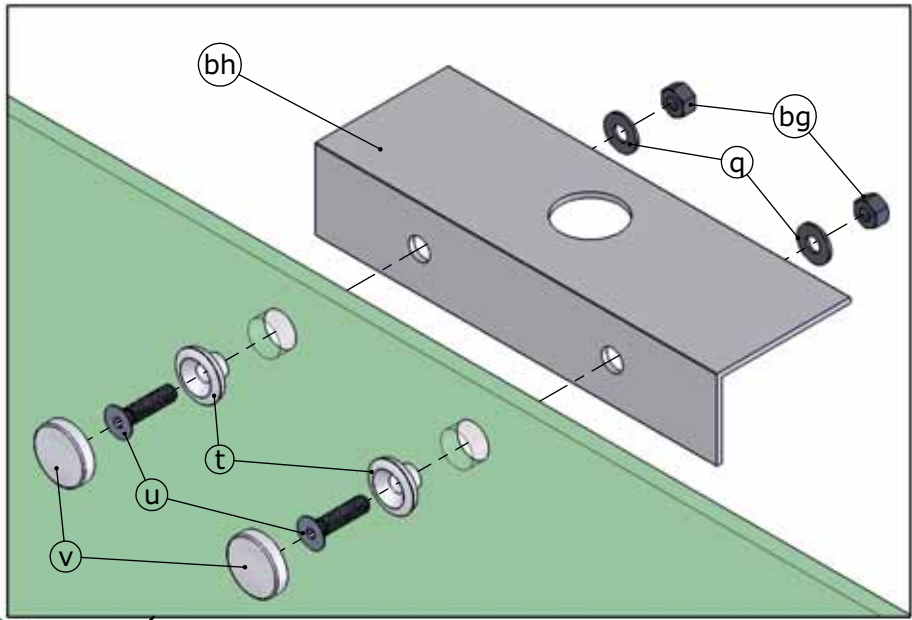

06

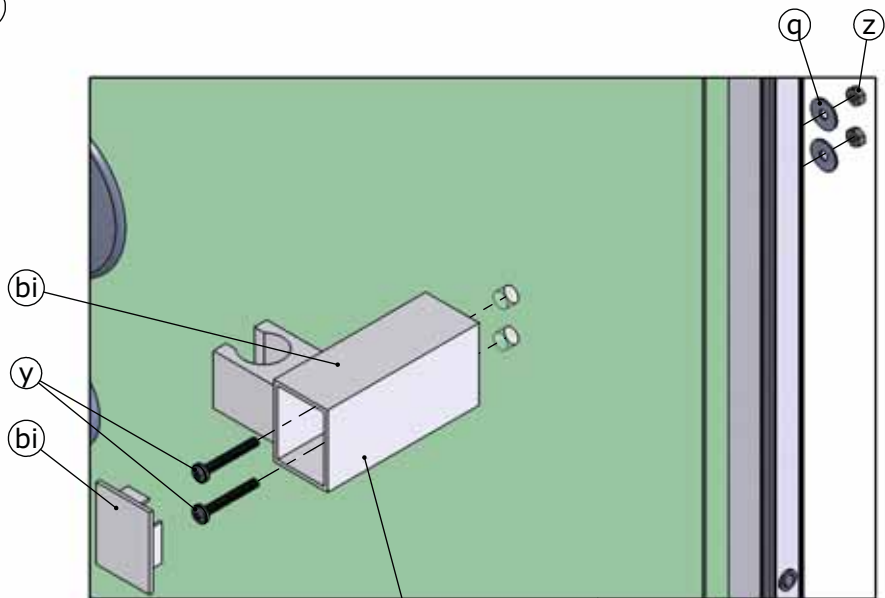

Inverser suivant le sens de montage.
 Fit left or right hand depending on installation.
 Invertir según el sentido del montaje.
 Keer om volgens de montagerichting.

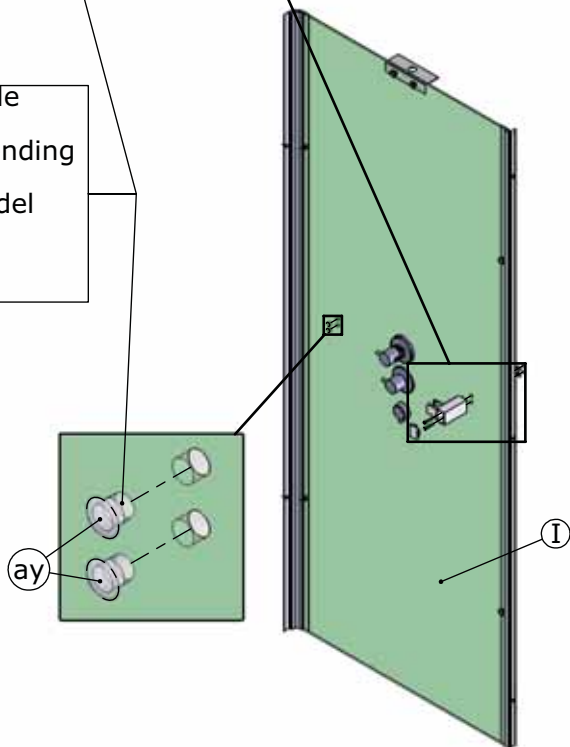

07

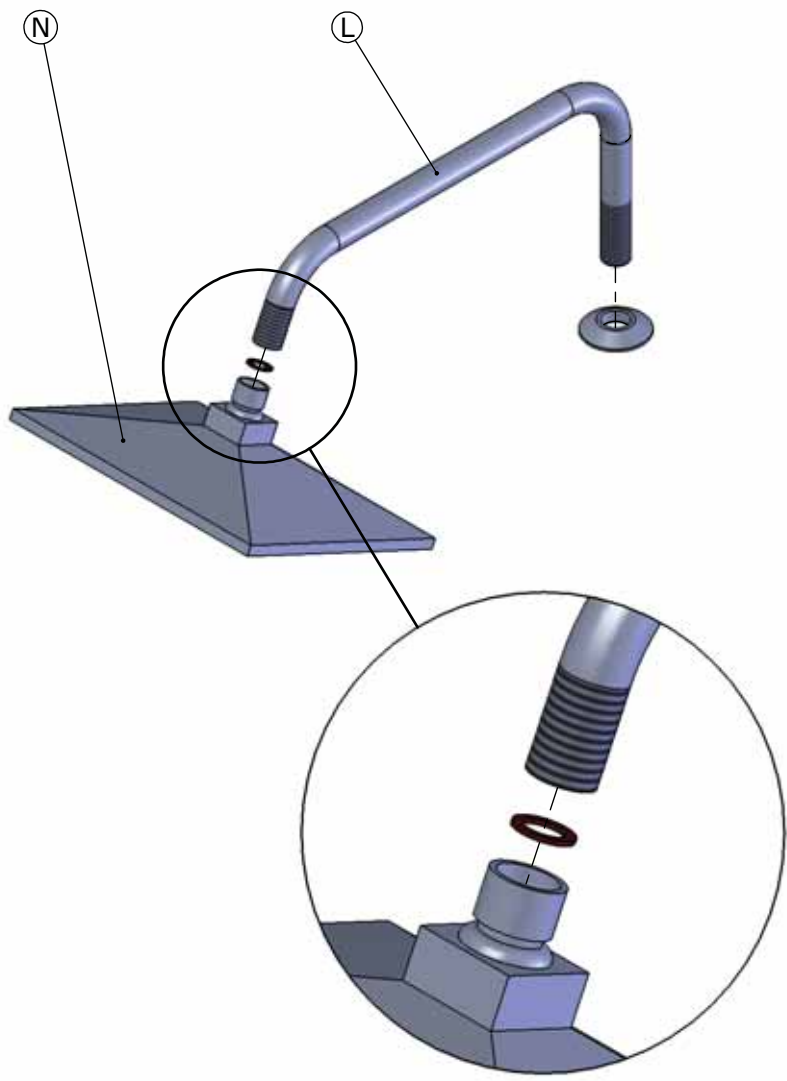

⑧

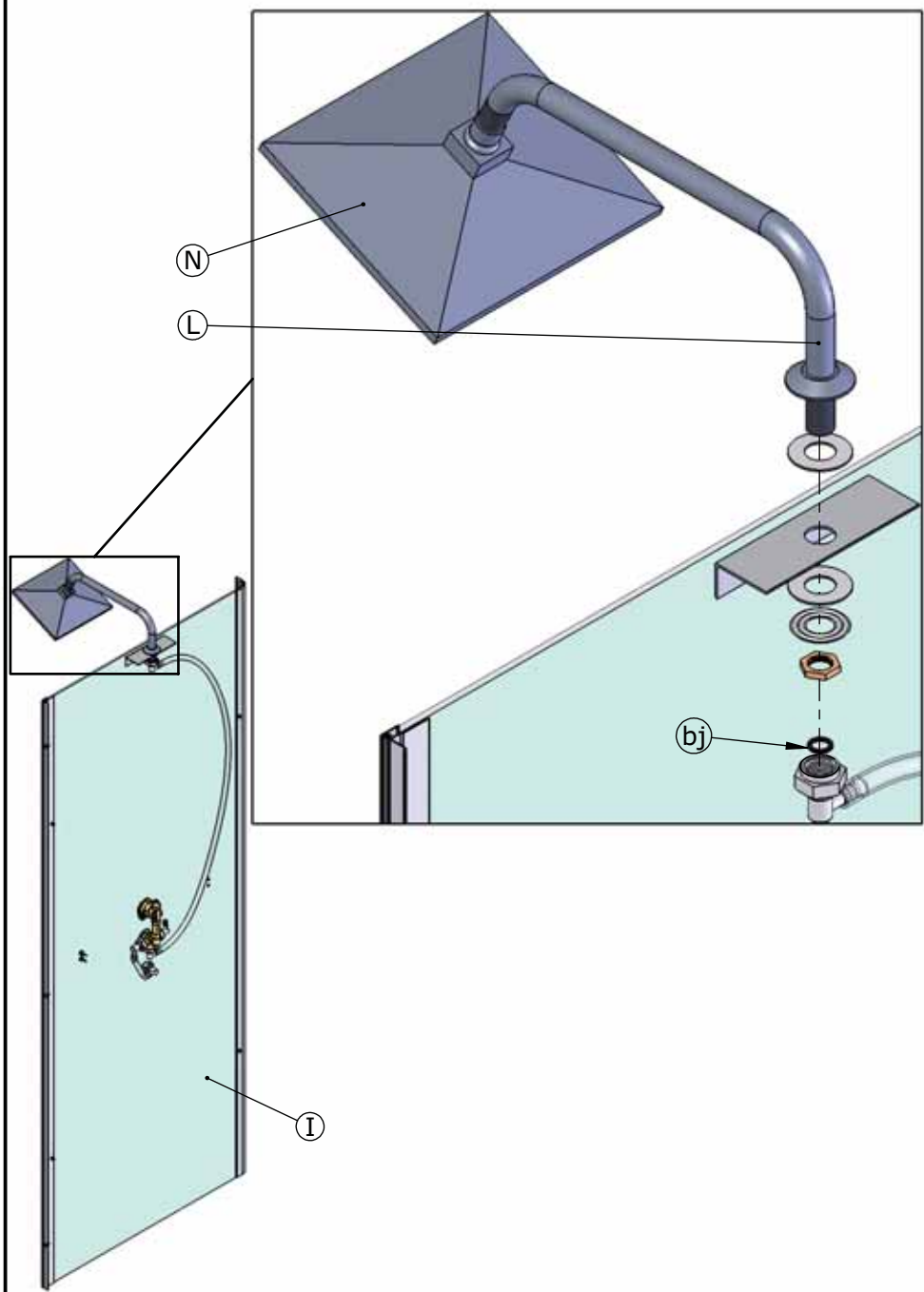

09 Sérigraphie à l'extérieur.
Screen printing on the outside.

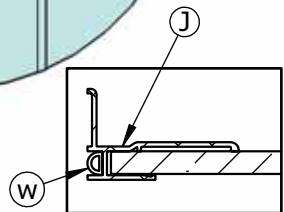
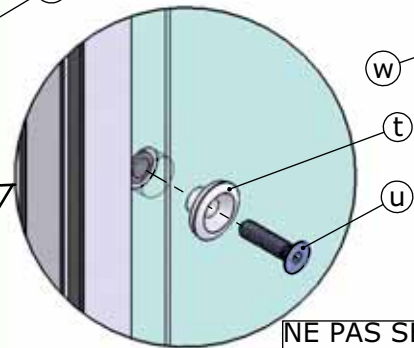
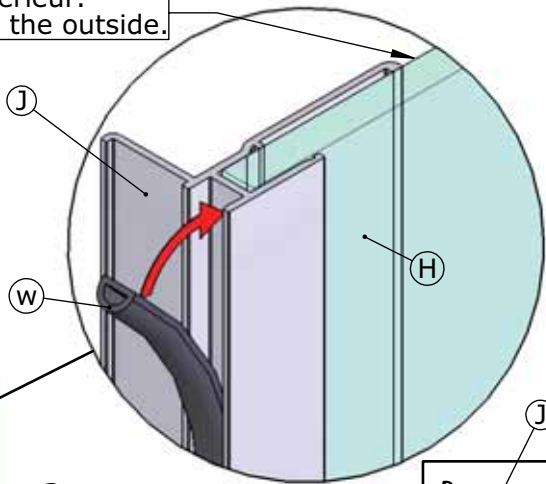

NE PAS SERRER.
DO NOT OVERTIGHTEN.
NO APRIETE.
NIET VASTSCHROEVEN.

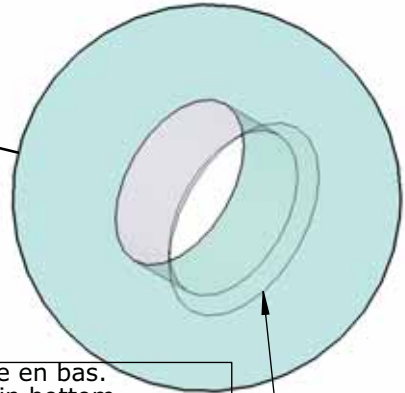

Le trou chanfreiné doit toujours être en bas.
The hole chamfers must always be in bottom.
El agujero biselado debe quedar siempre hacia abajo.
Het schuine gat moet altijd aan de onderzijde zitten.

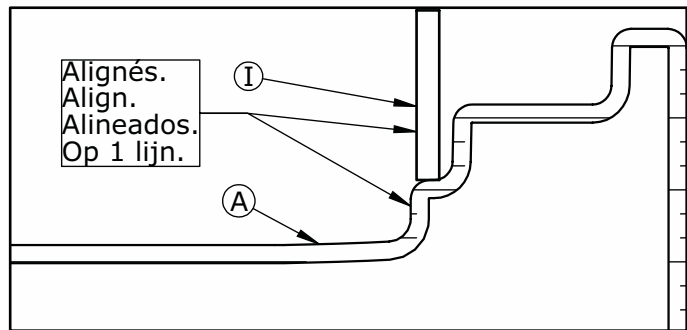
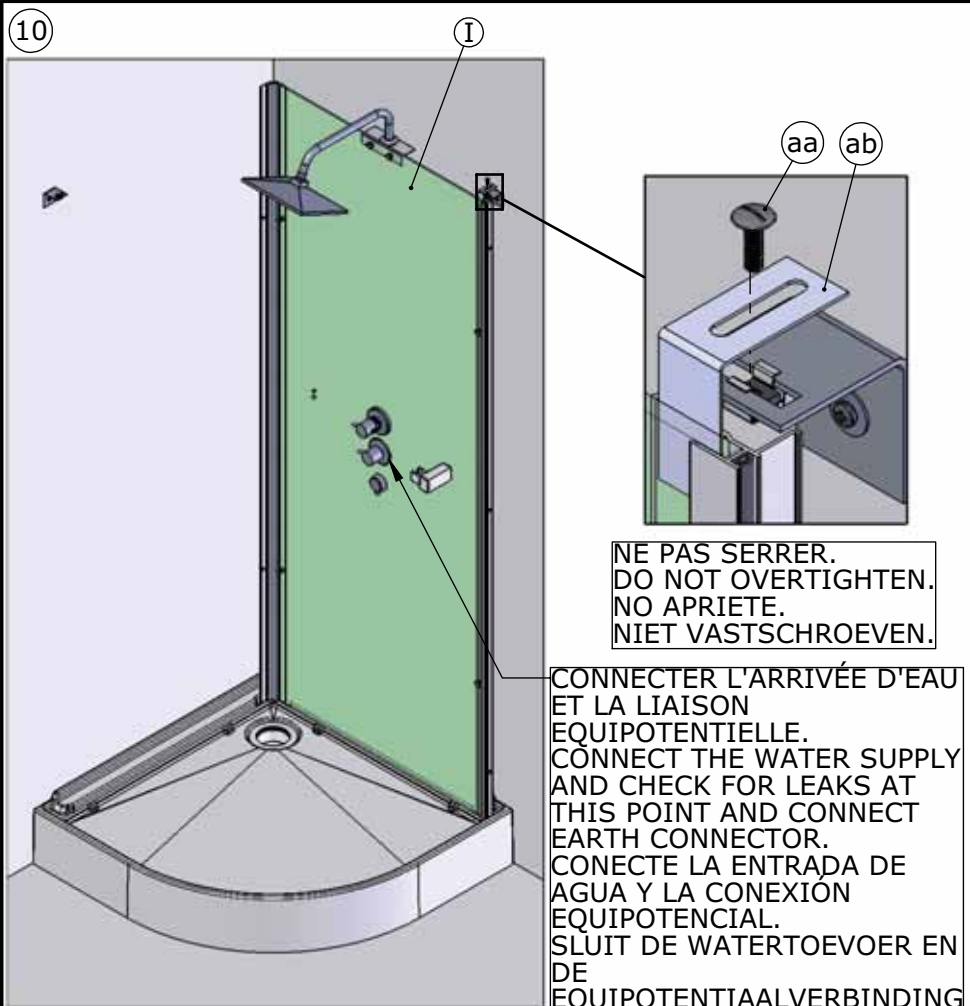

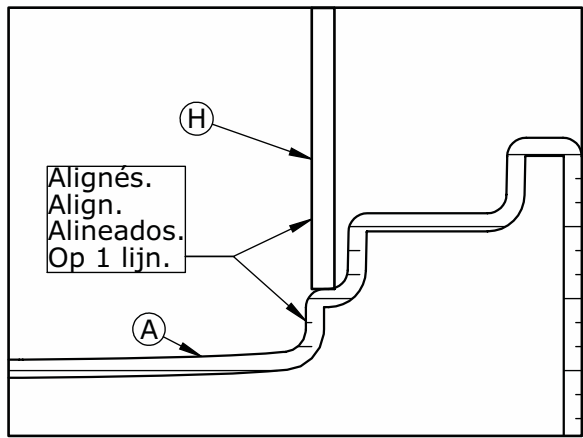
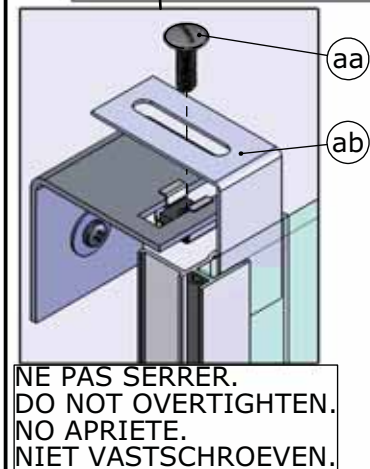
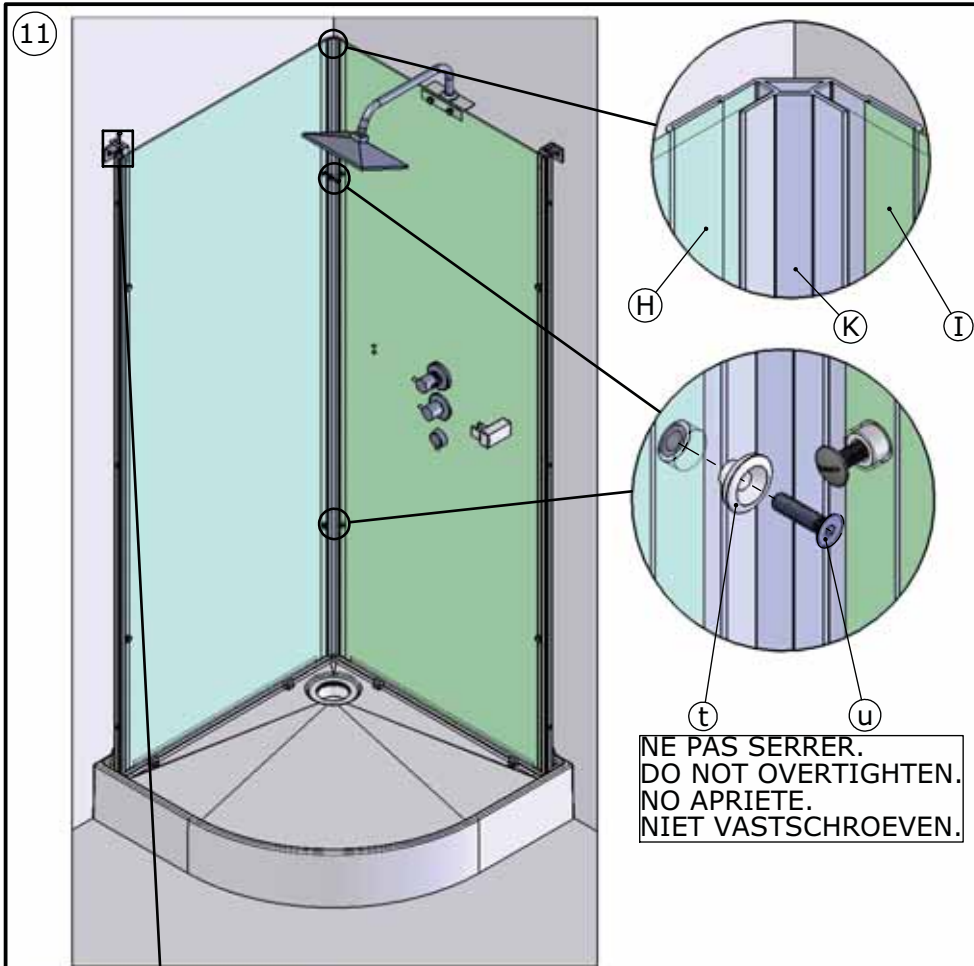

12

Sérigraphie à l'intérieur.
Screen printing on the inside.
Impresión en el interior.
Bedrukking aan de binnenzijde.

Perçages en haut.
Drill holes on top.
Perforaciones en la parte superior.
Gaatjes bovenaan.

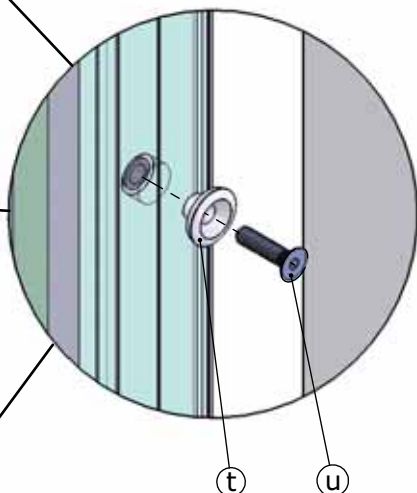
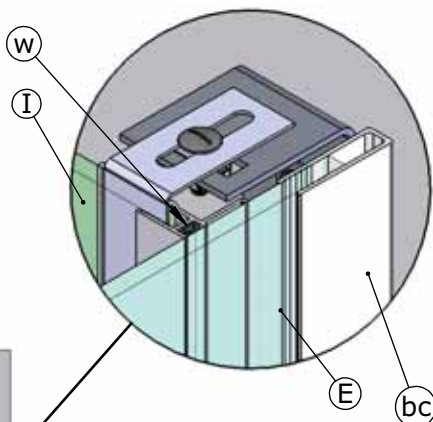
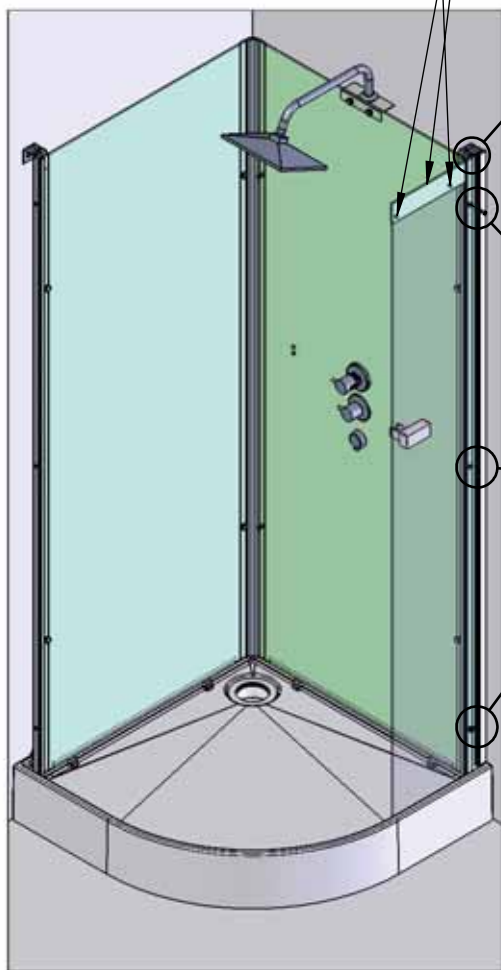

**NE PAS SERRER.
DO NOT OVERTIGHTEN.
NO APRIETE.
NIET VASTSCHROEVEN.**

13

Sérigraphie à l'intérieur.
Screen printing on the inside.
Impresión en el interior.
Bedrukking aan de binnenzijde.

Perçages en haut.
Drill holes on top.
Perforaciones en la parte superior.
Gaatjes bovenaan.

bc

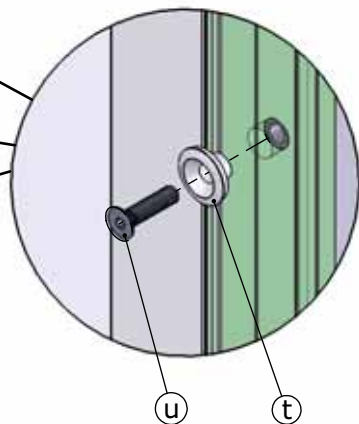
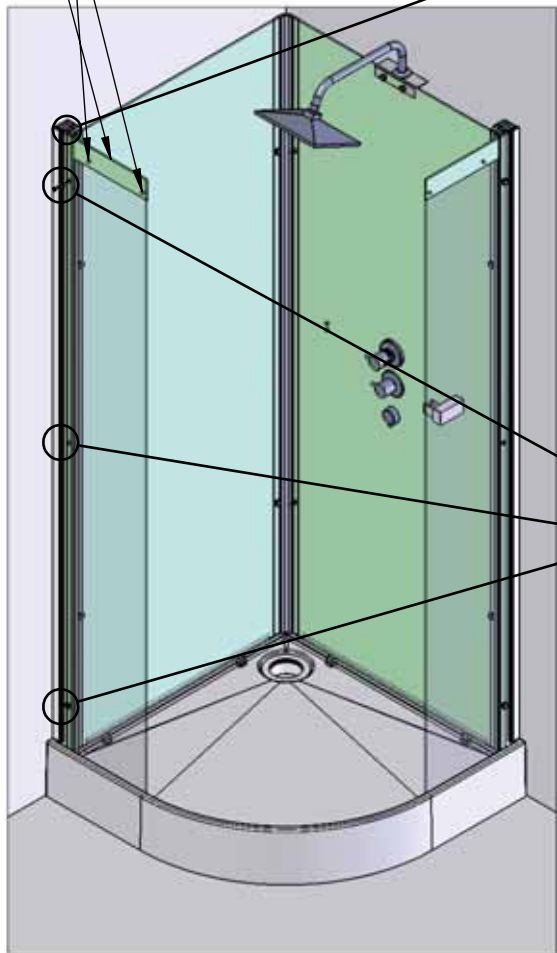
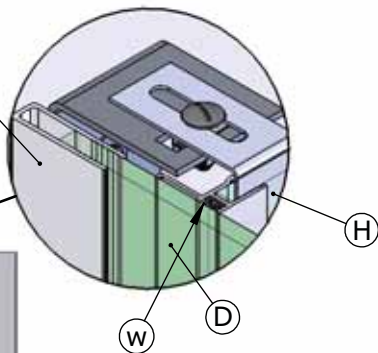

**NE PAS SERRER.
DO NOT OVERTIGHTEN.
NO APRIETE.
NIET VASTSCHROEVEN.**

14

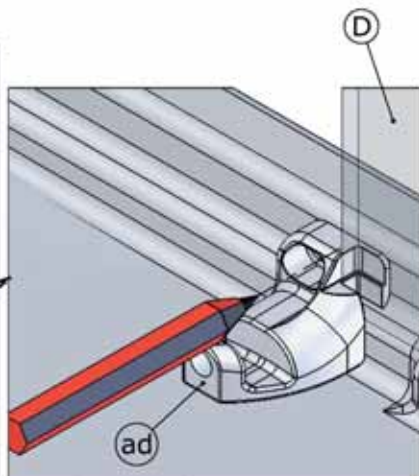
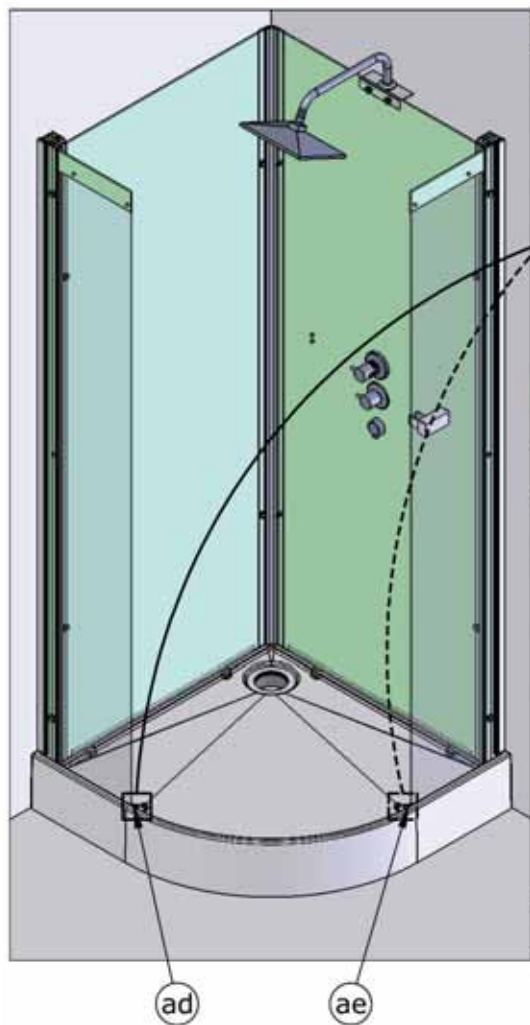

Ø 8 mm

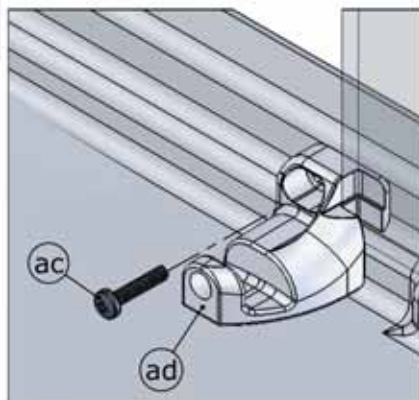
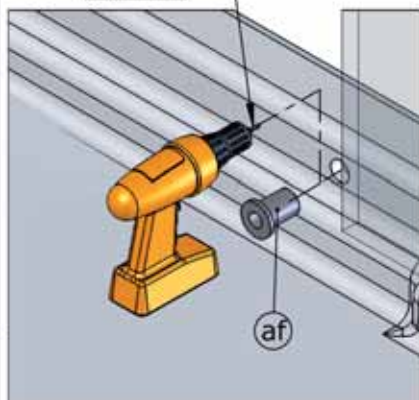

Assurer vous du bon positionnement
des verres avant de percer.
Ensure glass panels are fully home
before drilling.

15

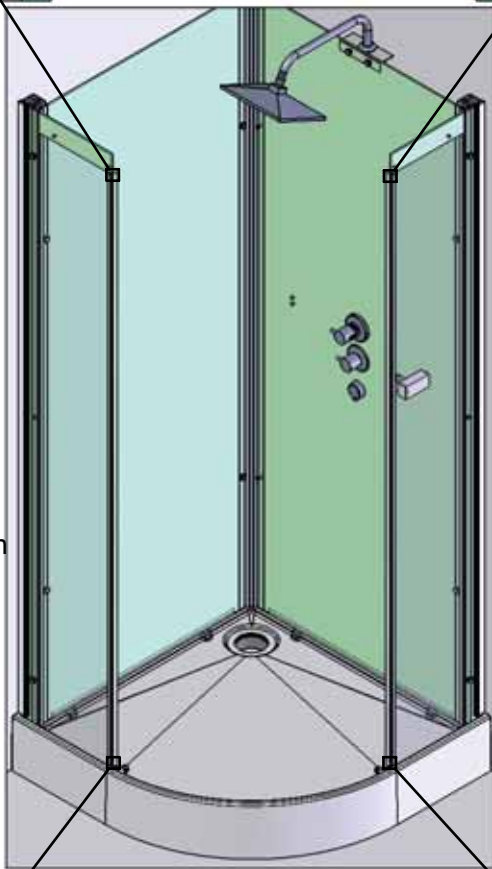
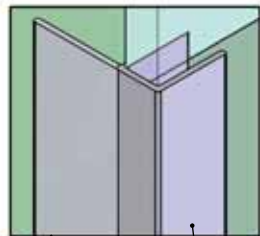
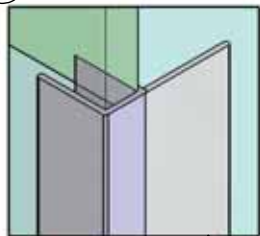

(al) Lg = 1925 mm

Lg = 1925 mm (al)

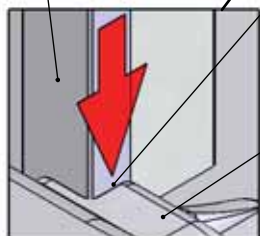

Positionner les joints (al) en buté dans les guides (ad) et (ae).
Position the edge (al) within the guides (ad) and (ae).
Coloque las juntas (al) introduciéndolas en las guías (ad) y (ae).
Plaats de afsluitingen (al) tussen de geleiders (ad) en (ae).

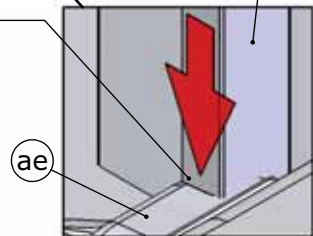

16

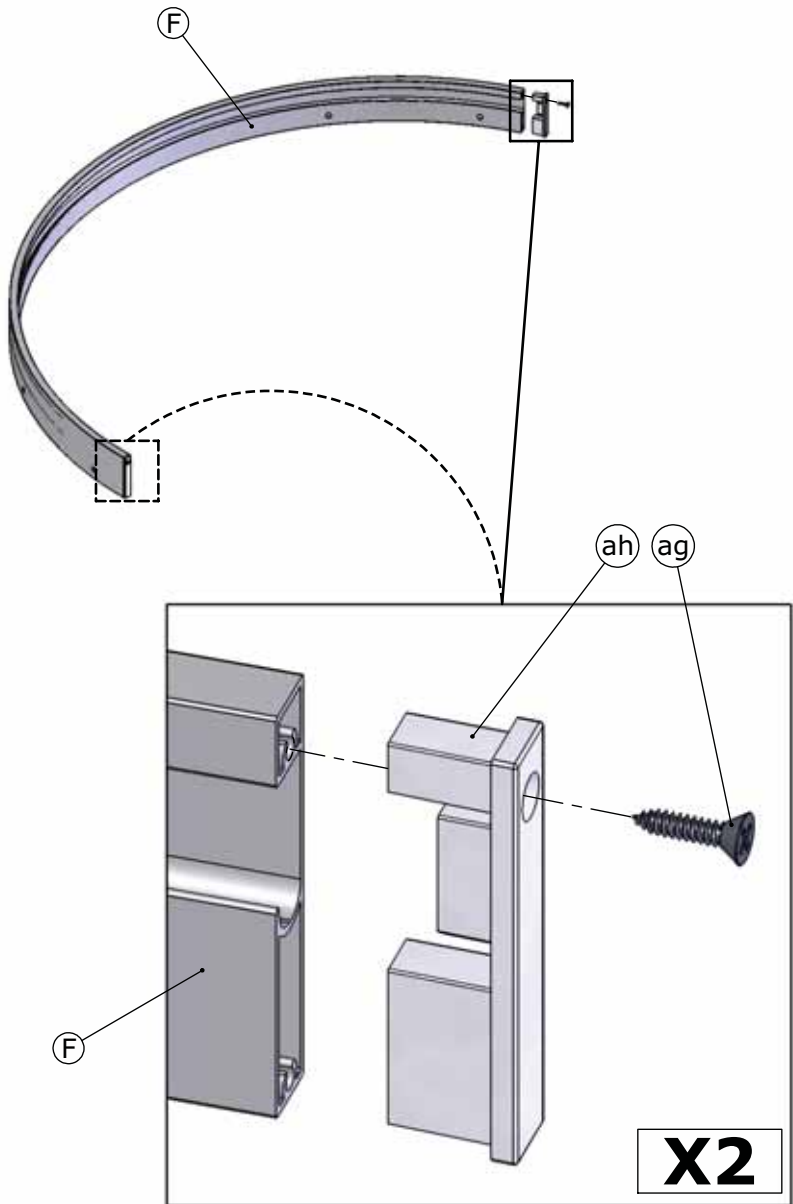

17

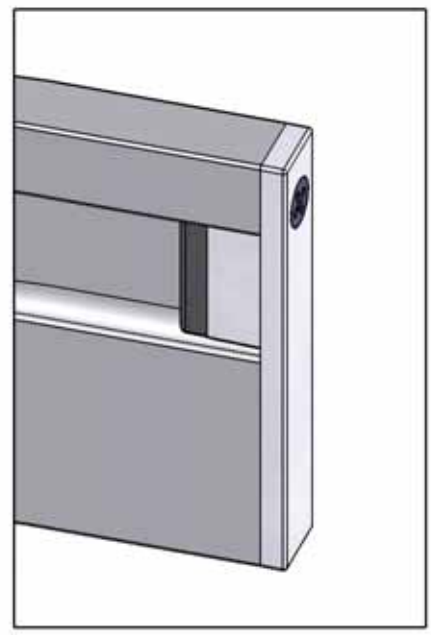
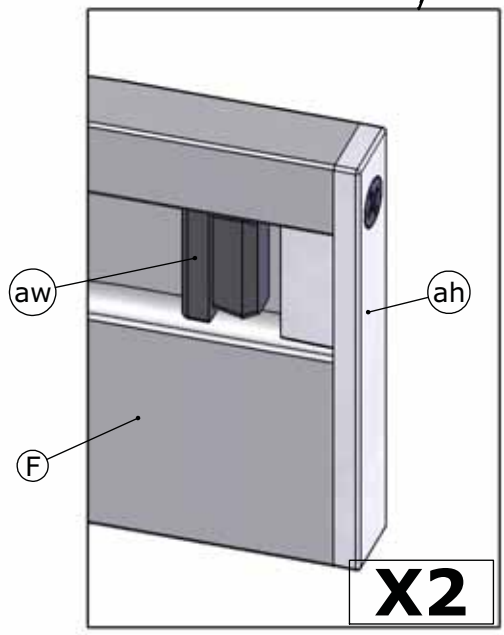
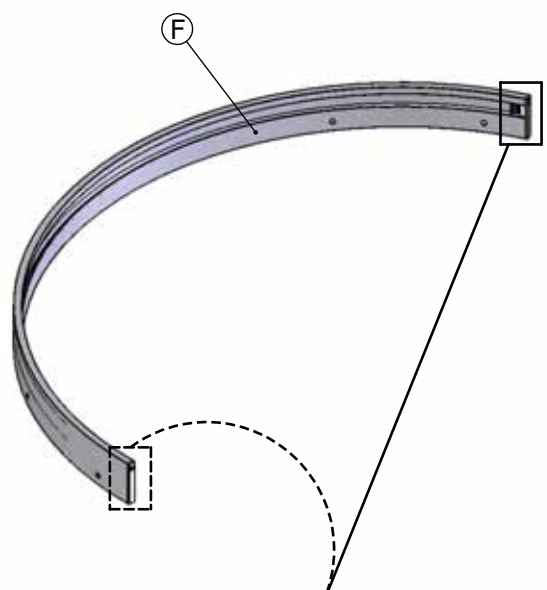

18

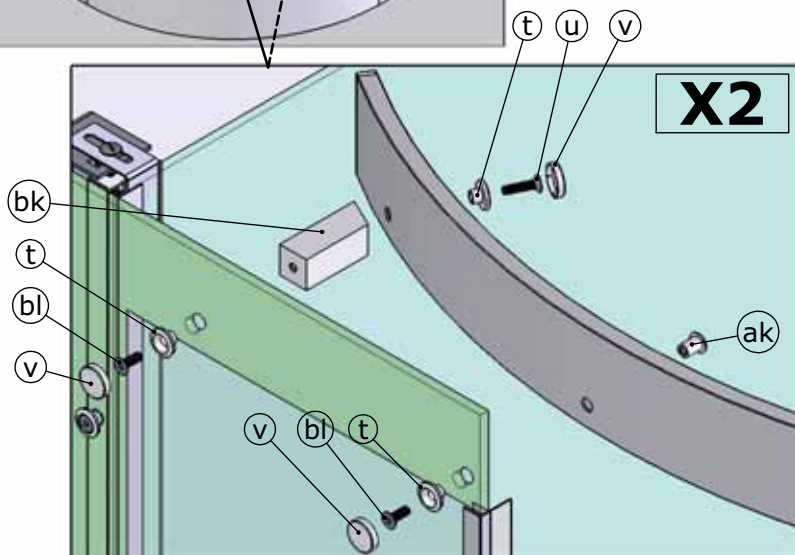
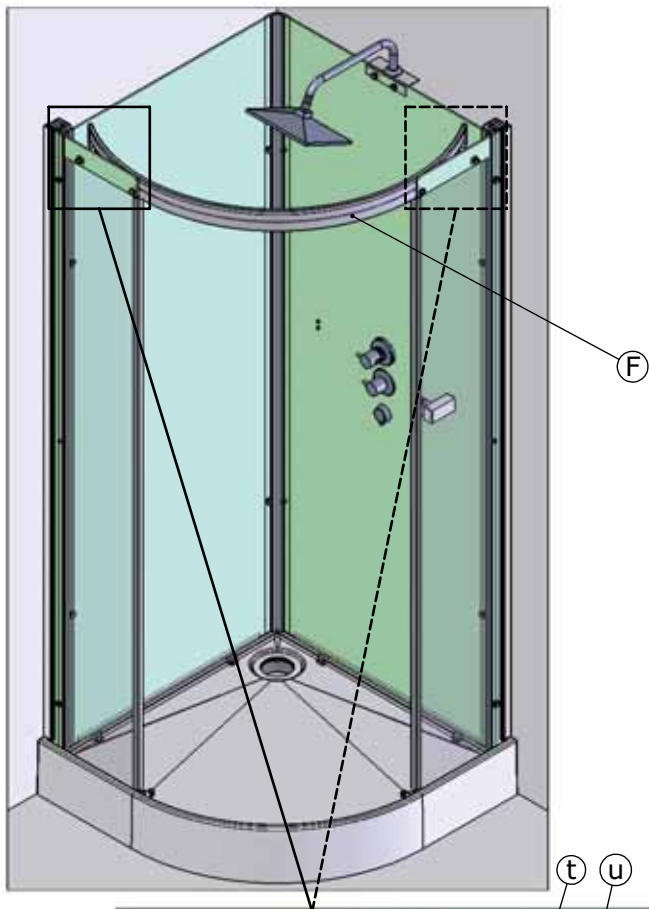

19

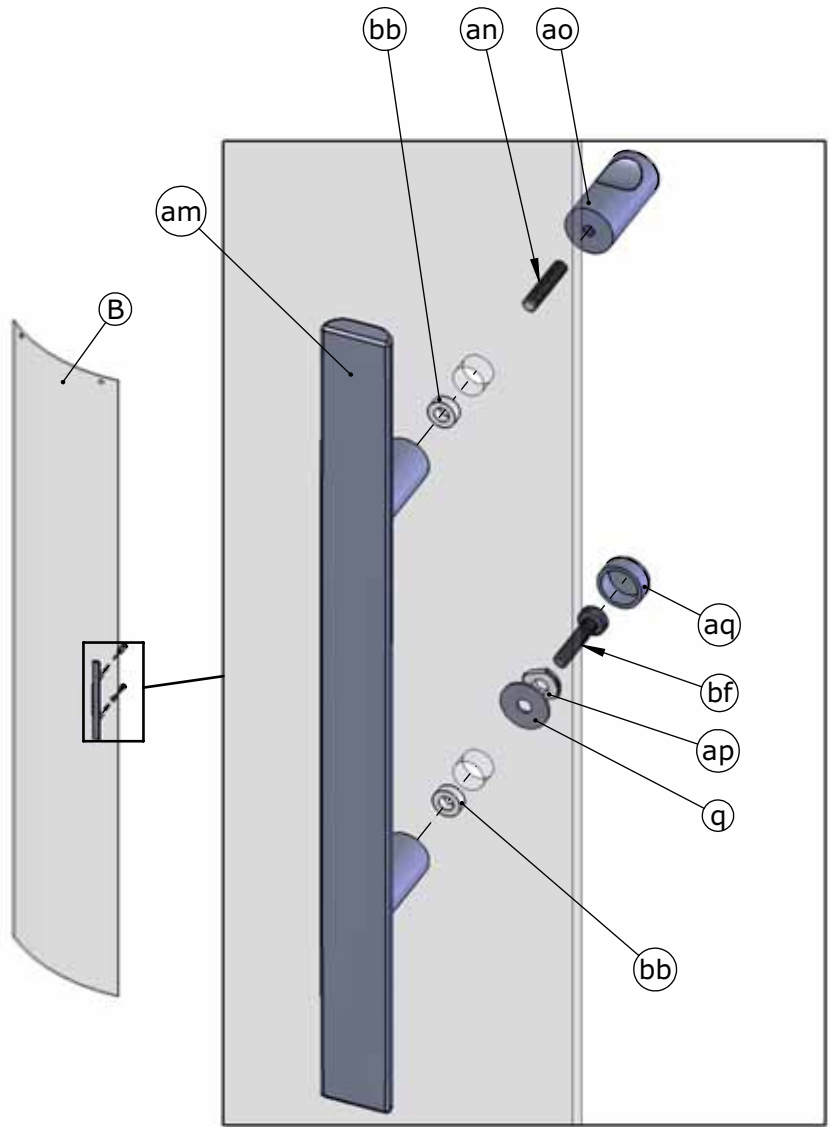

20

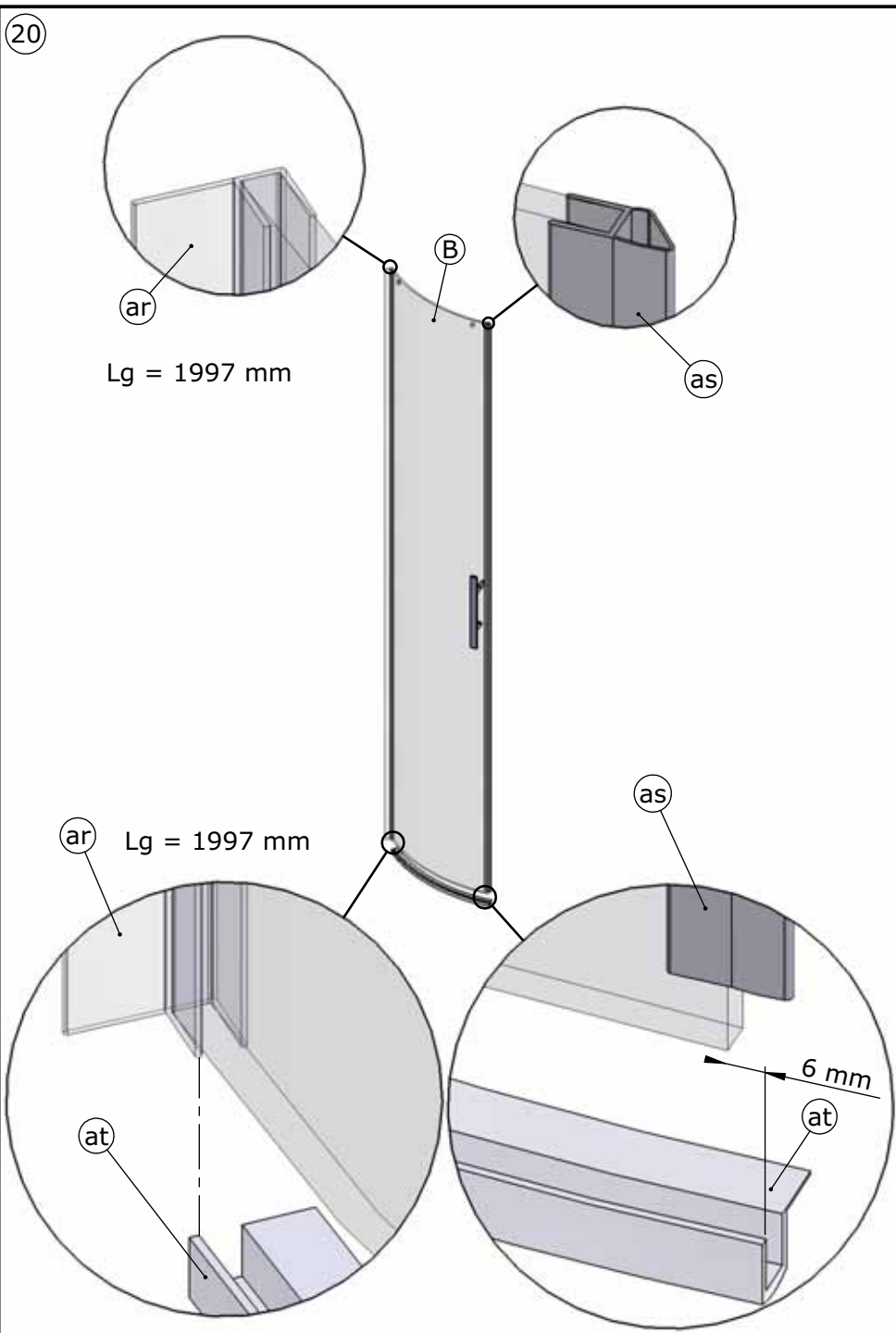

21

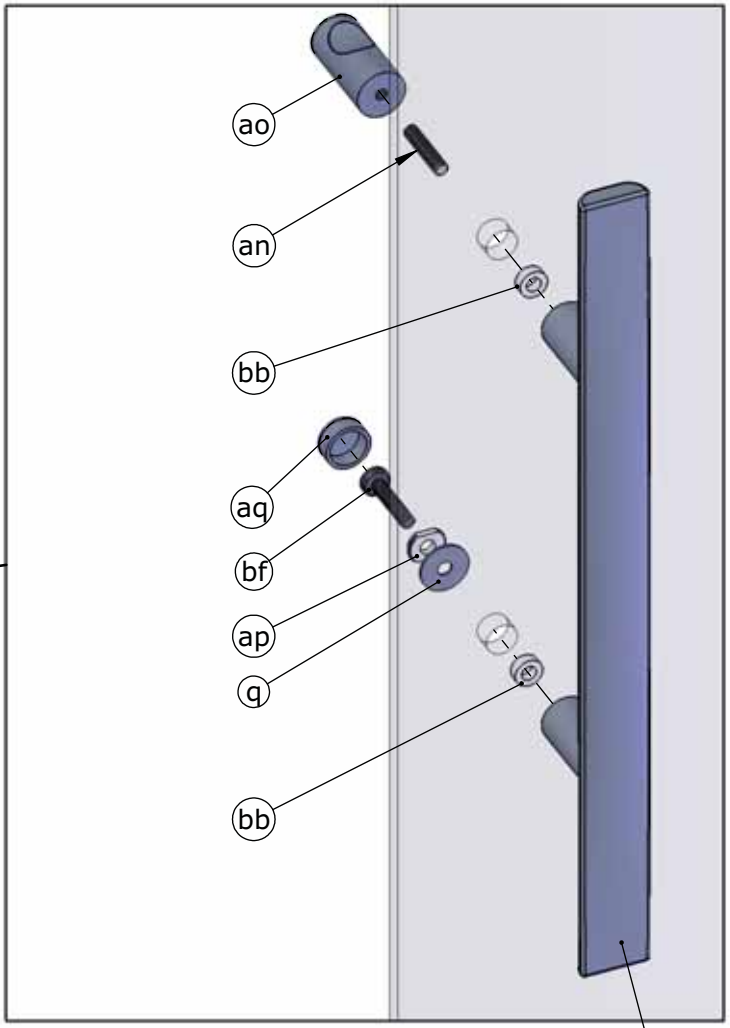
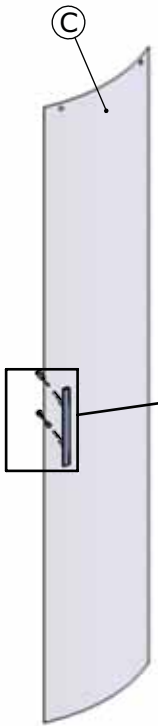

22

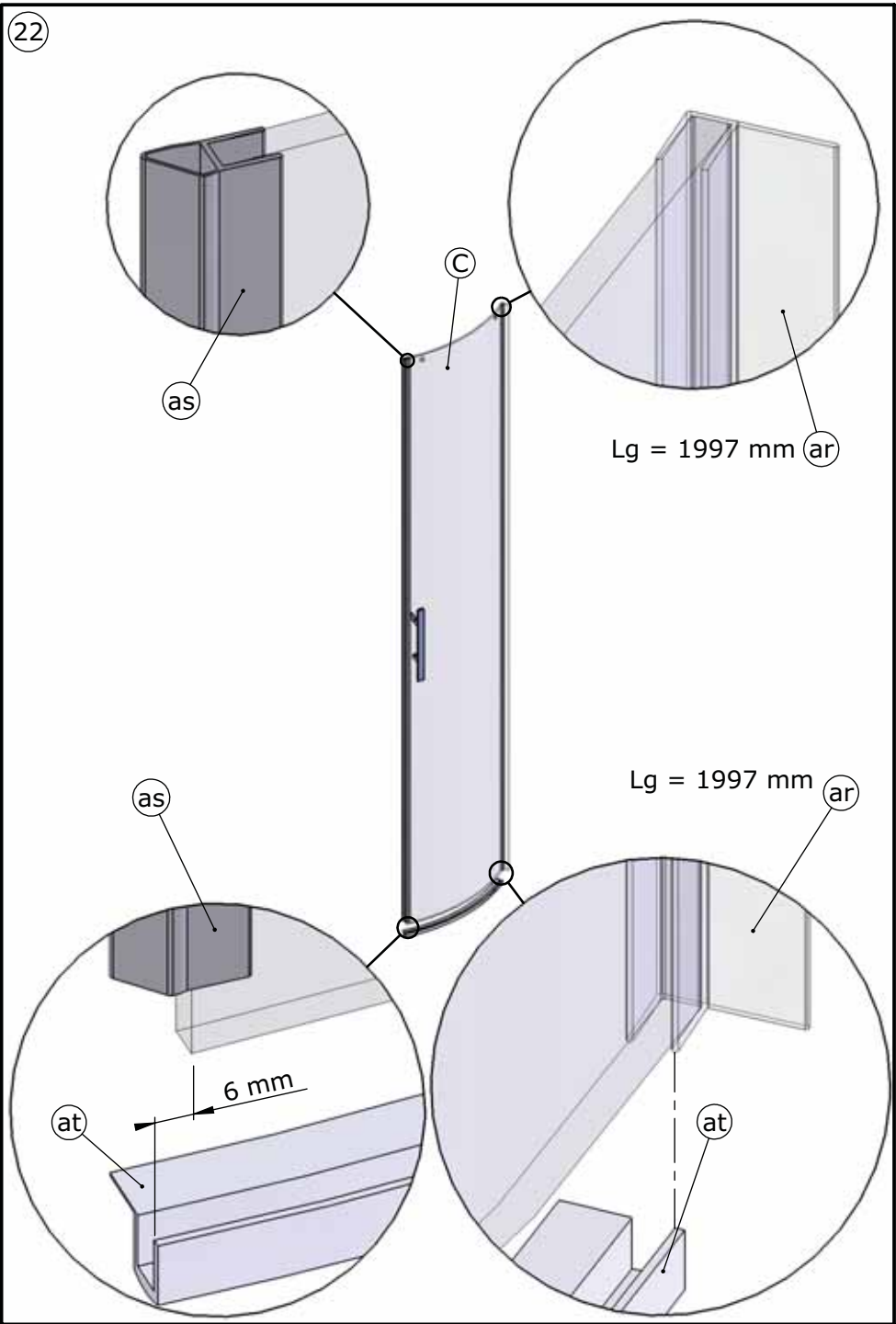

23

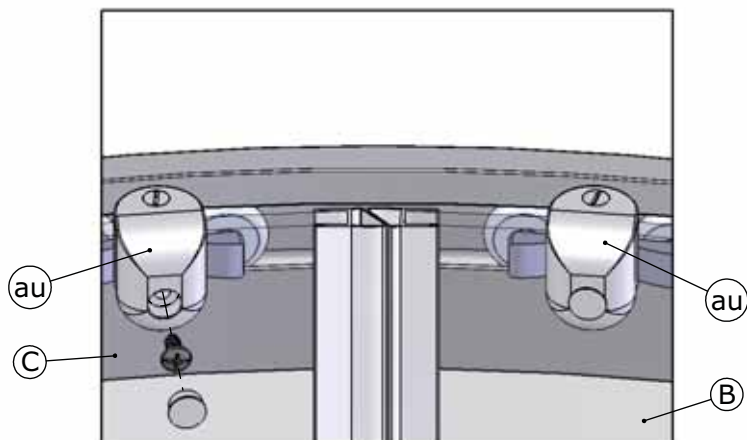

Placer les roulettes dans les rails puis fixer les portes dans les roulettes.
 Place the rollers into the top rail then attach the doors to the rollers.
 Ensure rollers are at the highest adjustment.
 Inserte las ruedas en los railes y fije las puertas a las ruedas.
 Plaats de wieltjes in de rails en zet ze daarna op de deuren vast.

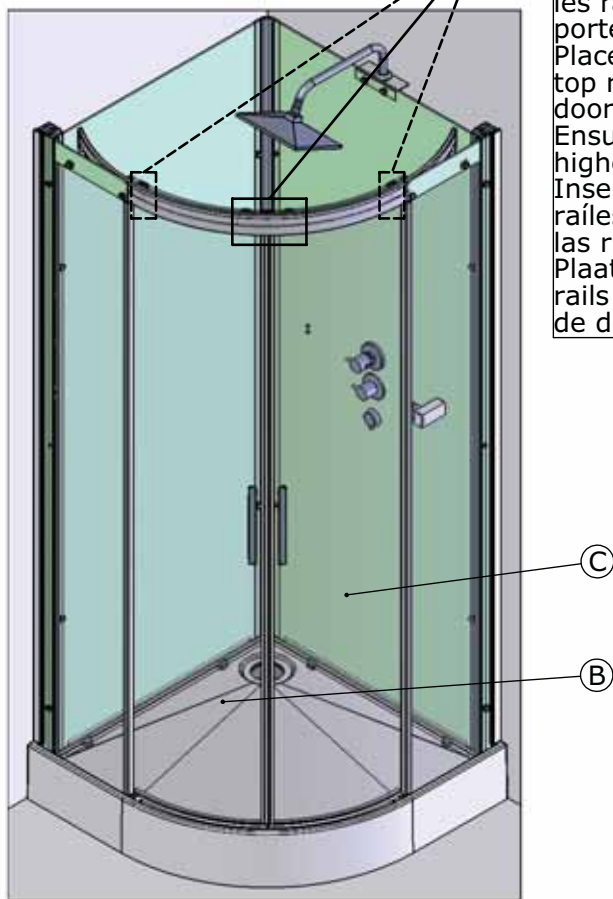

24

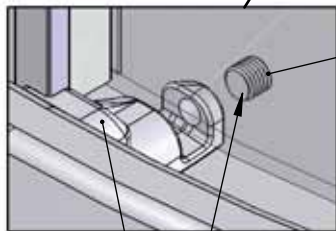
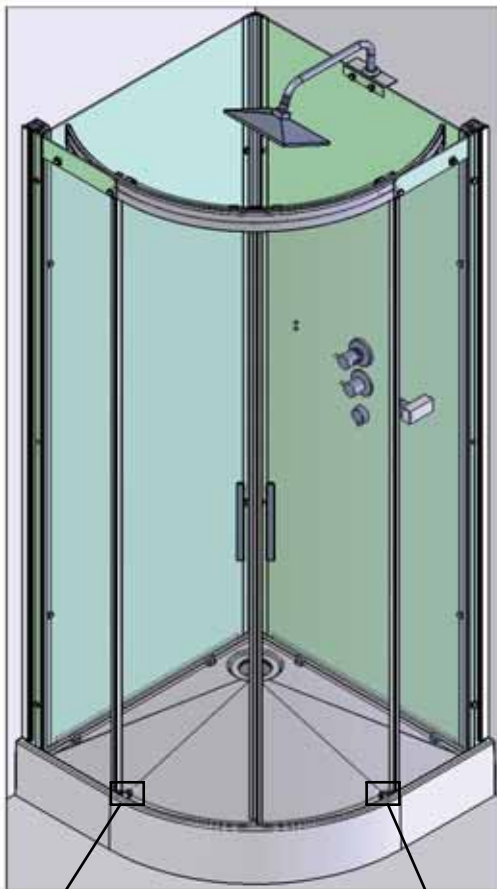

ad

av

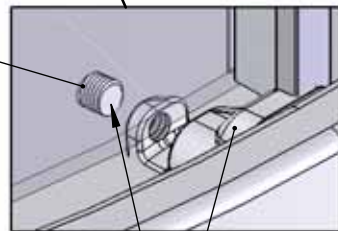

ae

Serrer, puis desserrer d'un
demi tour.
Hand tighten then unscrew
half a turn.
Apriete y desapriete media
vuelta.
Schroef vast en draai daarna
een halve slag terug.

25

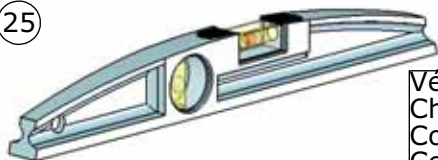

Vérifier l'aplomb de la cabine.
 Check that the cubicle is level.
 Compruebe la seguridad de la cabina.
 Controleer of de cabine waterpas staat.



Serrer.
 Tighten.
 Apriete.
 Vastschroeven.



Serrer.
 Tighten.
 Apriete.
 Vastschroeven.

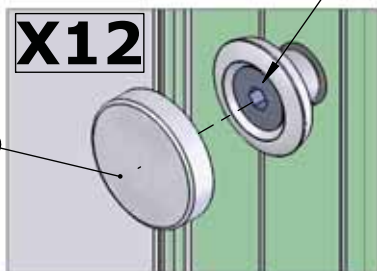

Serrer.
 Tighten.
 Apriete.
 Vastschroeven.

②6

Centrer les portes.
Adjust doors before fixing door stops.
Centrado de las puertas.
Deuren uitlijnen.

Coller les butées.
Attach the self adhesive door stops.
Pegue los toques.
Aanslag vastlijmen.

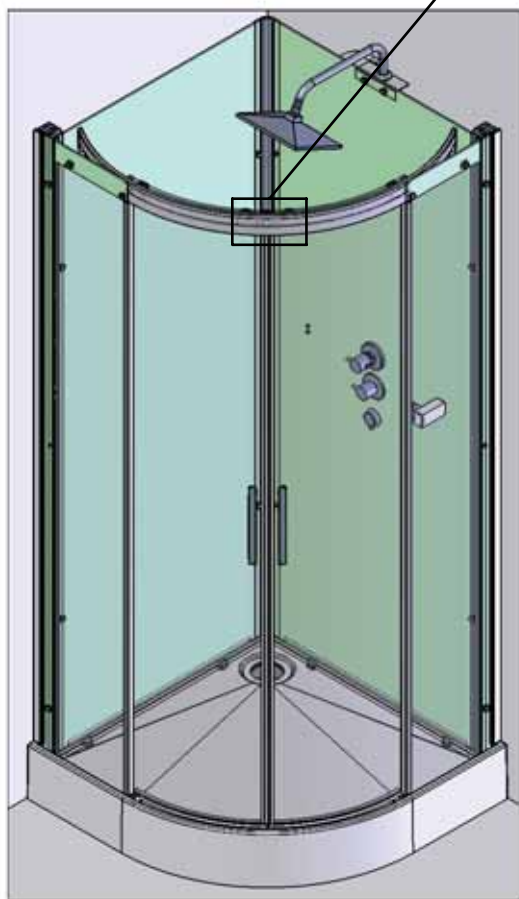
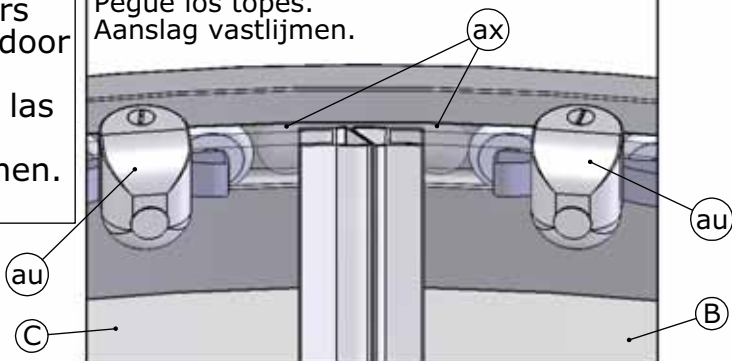

27

X

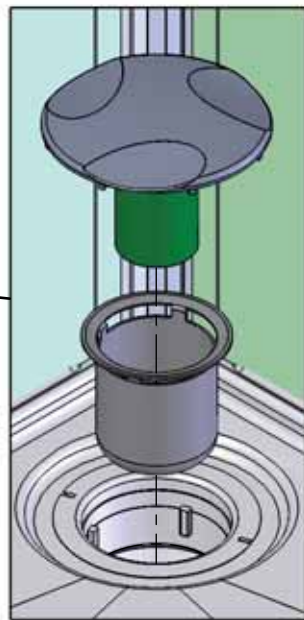
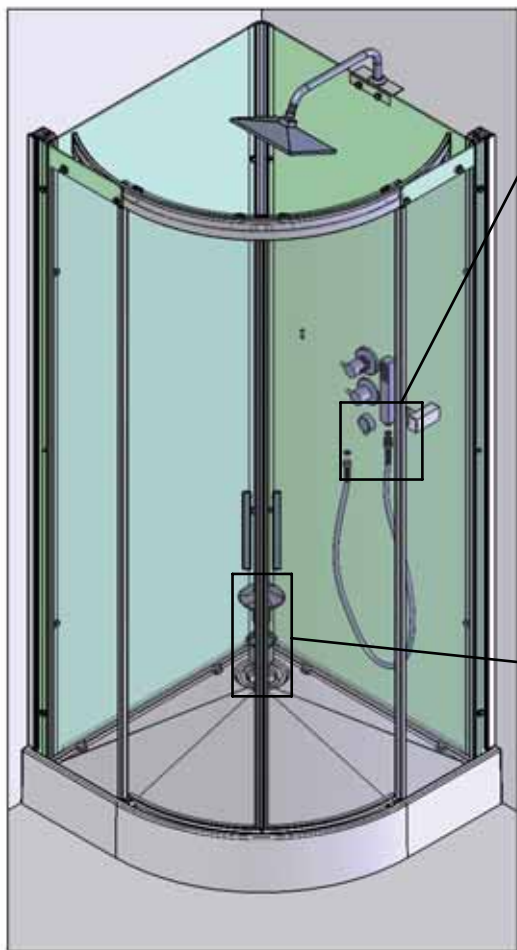
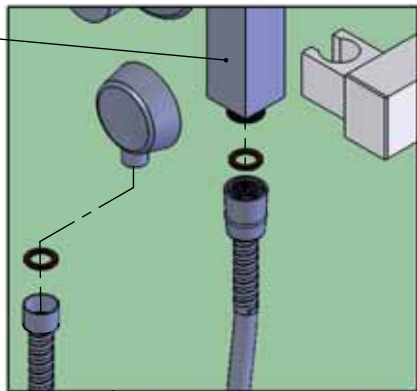

28

X4

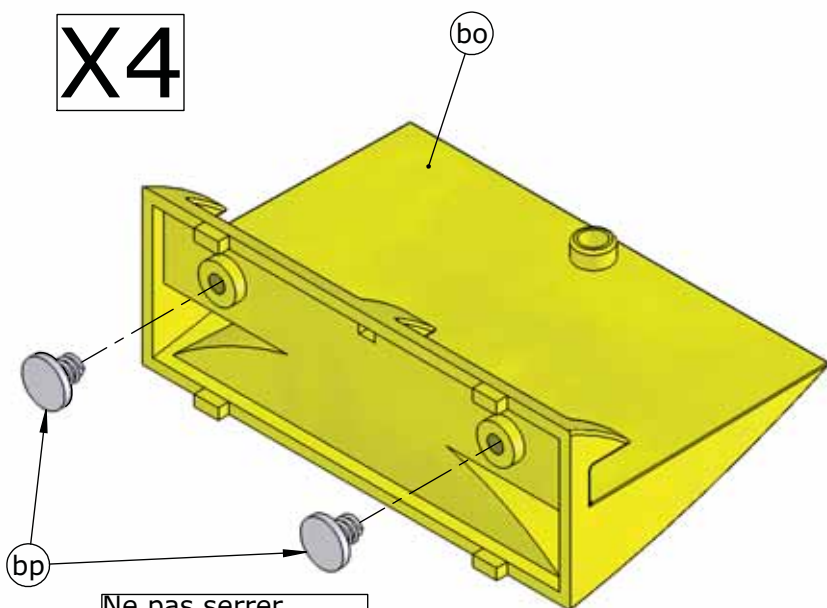

Ne pas serrer.
Do not overtighten.
No apriete.
Niet vastschroeven.

29

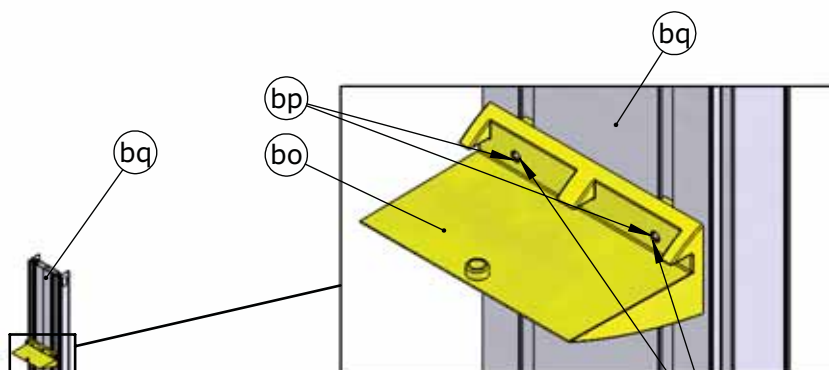

PLACER LES 4 SUPPORTS D'ETAGERE AUX HAUTEURS DESIREES PUIS SERRER.
 PLACE THE ADJUSTABLE SHELVES AT THE DESIRED HEIGHT THEN TIGHTEN.
 COLOQUE LOS 4 SOPORTES DE ESTANTE A LA ALTURA QUE DESEE Y FIJELOS.
 PLAATS DE VIER STEUNEN VAN HET REK OP DE GEWENSTE HOOGTE EN SCHROEF ZE DAARNA VAST.

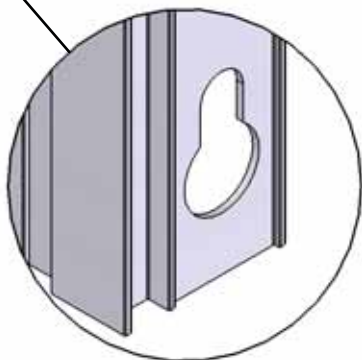

30

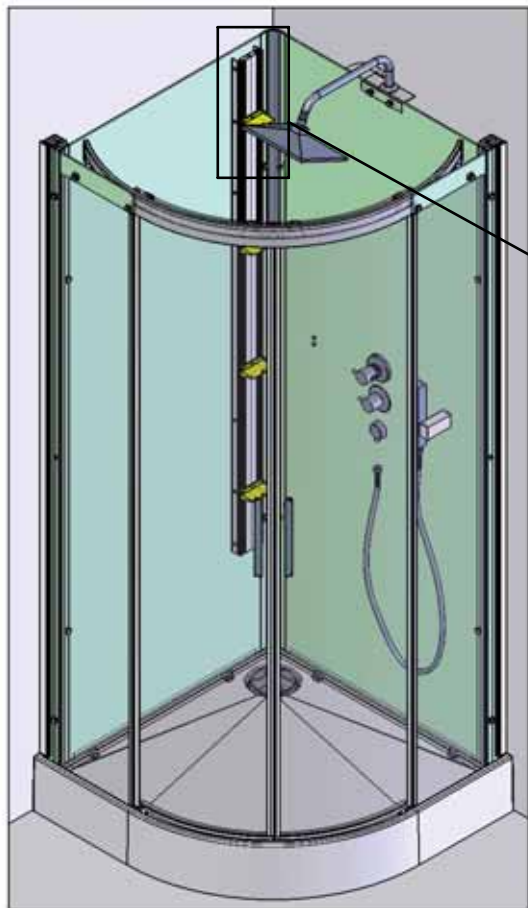

POSER (bq) SUR LES
VIS, PUIS SERRER.
FIX (bq) OVER THE
SCREWS THEN
TIGHTEN.
ABOYE (bq) SOBRE
LOS TORNILLOS Y
APRIETE.
PLAATS (bq) OP DE
SCHROEVEN EN
SCHROEF DAARAN
VAST.

31

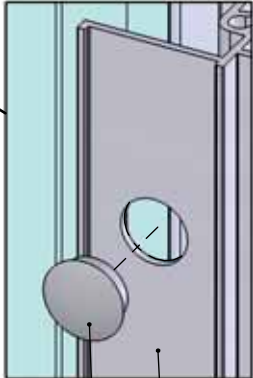
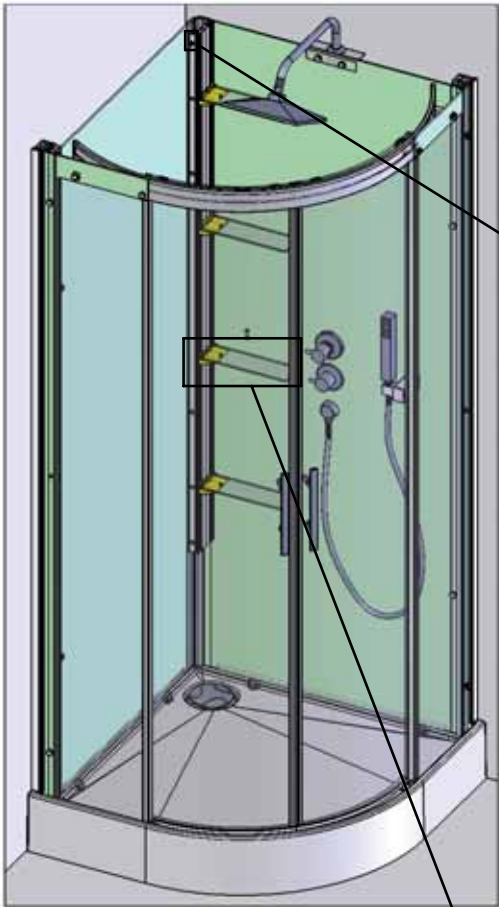

bs

bq

x4

br

bo

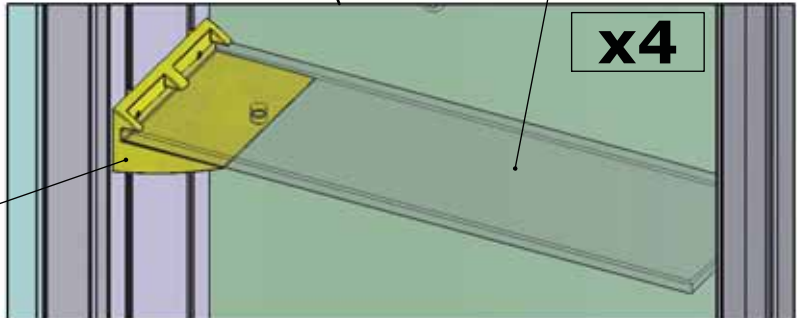

x4

32

Sérigraphie à l'intérieur.
Screen printing on the
inside.
Impresión en el interior.
Bedrukking aan de
binnenzijde.

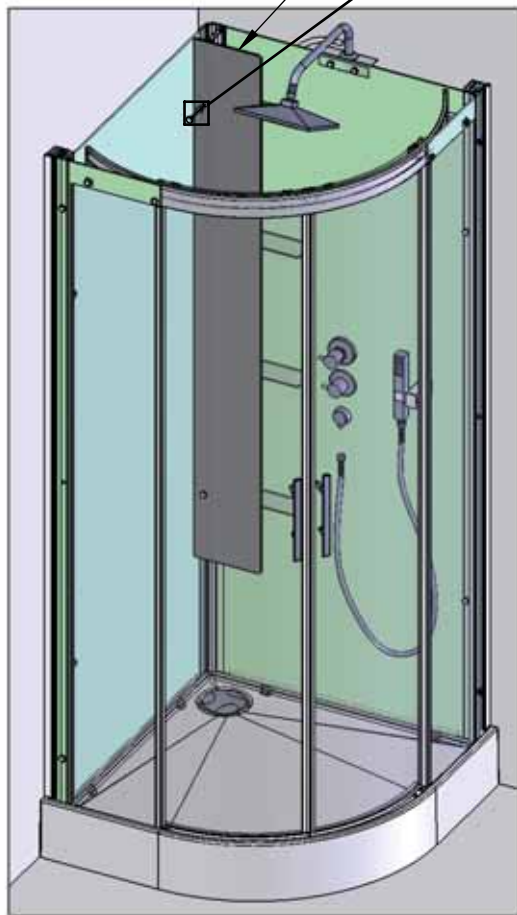
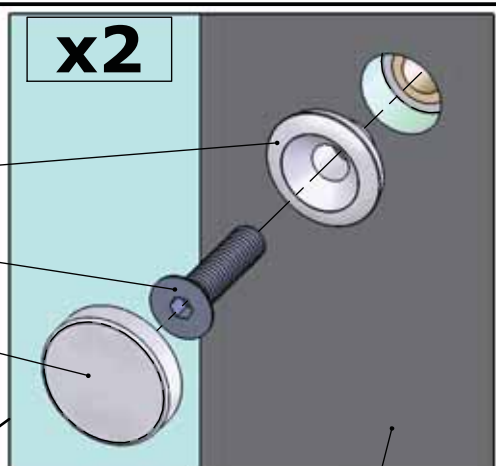

33

**Réglage des portes.
Adjust the doors.
Ajuste de las puertas.
Deuregelung.**

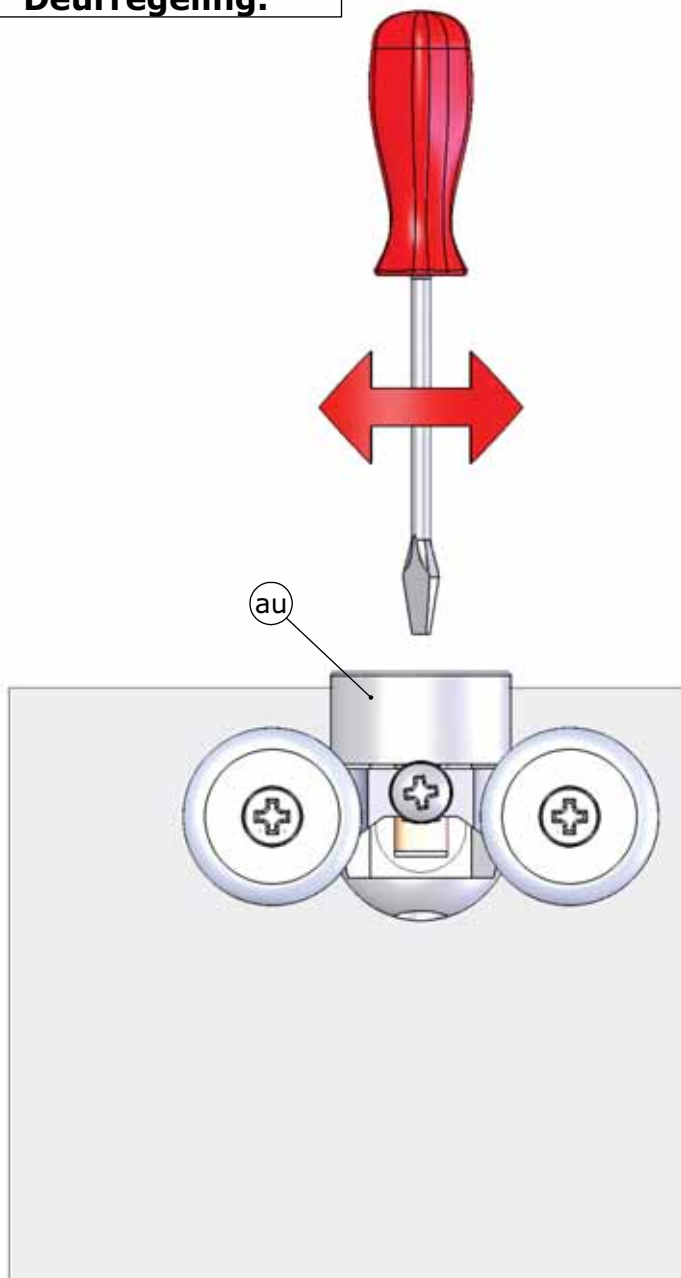



-F-

POUR LA PROTECTION ELECTRIQUE DE VOTRE DOUCHE, IL EST NECESSAIRE DE RELIER LES ORGANES METALLIQUES DE VOTRE PRODUIT AU CIRCUIT EQUIPOTENTIEL DE VOTRE INSTALLATION.

VOUS POUVEZ CONTACTER VOTRE INSTALLATEUR HABITUEL, IL SAURA VOUS CONSEILLER.

-GB-

FOR THE ELECTRONIC PROTECTION OF YOUR SHOWER, THE METAL PARTS OF YOUR PRODUCT SHOULD BE CONNECTED TO THE EQUIPOTENTIAL CIRCUIT OF YOUR INSTALLATION.

CONTACT YOUR USUAL SHOWER FITTER FOR ADVICE.

-NL-

VOOR DE ELEKTRISCHE BESCHERMING VAN UW DOUCHE MOETEN DE METALEN DELEN VAN UW PRODUCT WORDEN AANGESLOTEN OP HET EQUIPOTENTIALE CIRCUIT VAN UW INSTALLATIE.

NEEM HIERVOOR CONTACT OP MET UW NORMALE INSTALLATEUR, HIJ KAN U ADVISEREN.

-I-

PER GARANTIRE LA PROTEZIONE ELETTRICA DELLA DOCCIA OCCORRE COLLEGARE LE PARTI METALLICHE AL CIRCUITO EQUIPOTENZIALE DELL'APPARECCHIO.

CHIEDERE CONSIGLIO ALL'ELETTICISTA DI FIDUCIA

-ES-

PARA LA PROTECCIÓN ELÉCTRICA DE SU DUCHA, SERÁ NECESARIO CONECTAR LOS ELEMENTOS METÁLICOS DE SU PRODUCTO AL CIRCUITO EQUIPOTENCIAL DE SU INSTALACIÓN.

PÓNGASE EN CONTACTO CON SU INSTALADOR HABITUAL, ÉSTE SABRÁ ACONSEJARLE.

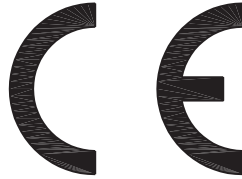

AQUAPRODUCTION, Site industriel, F - 44680 Chéméré

09

EN 14428

Paroi de douche, fabriquée
dans un matériau de vitrage donné

Aptitude au nettoyage : réussite

Résistance à l'impact/propriétés de fragmentation : réussite

Durée : réussite



SAV
SERVICE HELPLINES
ASSISTENZA POST-VENDITA
SERVICIO POSTVENTA

FRANCE

N°Azur 0 810 05 1998
prix d'un appel local

UK

020 8842 0033

IRELAND

04697 33102

DEUTSCHLAND

0800 82 27 82 0

ITALIA

(0382) 6181

OSTEREICH

(0222) 21 402 16 0

SCHWEIZ

(01) 748 17 44

ESPANA

00 34 93 381 85 97

NEDERLAND

(0) 475 487 100

BELGIE

31 (0) 475 487 100

BELGIQUE

32 (0) 67 44 29 59

РОССИЯ

963 19 40, 773 67 22